

Sun Ultra™ 80 Workstation

Just the Facts



Copyrights

© 1999 Sun Microsystems, Inc. All Rights Reserved.

Sun, Sun Microsystems, the Sun logo, Ultra, PGX32, Sun Workstation, Sun Enterprise, Starfire, Solaris, Catalyst, SunPCi, PGX, PGX32, VIS, XGL, XIL, Java, Java 3D, SunCD, Sun StorEdge, Solstice, Solstice AdminTools, SunVTS, Solstice Enterprise Agents, ShowMe How, ShowMe TV, TurboGX, TurboGXplus, S24, OpenWindows, SunCD 2Plus, Netra, SunButtons, SunDials, SunPCI, Sun Quad FastEthernet, SunFDDI, SunLink, SunHSI, SunATM, SunVideo, SunVideo Plus, Sun StorEdge ArrayStart, SunCamera, SunMicrophone, SunSpectrum, SunStart, SunSpectrum Platinum, SunSpectrum Gold, SunSpectrum Silver, SunSpectrum Bronze, SunVIP, SunSolve, SunSolve EarlyNotifier, SunClient, JavaStation, NFS, and Sun Video Plus are trademarks, registered trademarks, or service marks of Sun Microsystems, Inc. in the United States and other countries.

All SPARC trademarks are used under license and are trademarks or registered trademarks of SPARC International, Inc. in the United States and other countries. Products bearing SPARC trademarks are based upon an architecture developed by Sun Microsystems, Inc.

OpenGL is a trademark of Silicon Graphics, Inc., which may be registered in certain jurisdictions.

UNIX is a registered trademark in the United States and in other countries, exclusively licensed through X/Open Company, Ltd.

PostScript and Display PostScript are trademarks of Adobe Systems, Inc., which may be registered in certain jurisdictions.

Netscape is a trademark of Netscape Communications Corporation.

Positioning



Figure 1. Sun Ultra™ 80 workstation

Multiprocessing Power on the Desktop

The Sun Ultra™ 80 workstation brings multiprocessing power, industry-standard PCI I/O, and dual-UPA graphics capability to the desktop. This next-generation workstation uses the processing power of UltraSPARC™-II processors, PGX32™ and Sun Elite3D graphics technology, UltraSCSI disks, and the innovative high-performance peripheral component interconnect (PCI) I/O bus. With the tower system enclosure, Sun Ultra 80 workstation provides all the modular and expandable features that users have grown to expect from Sun Workstation™ systems. Sun's commitment to high-performance computing means the Ultra 80 workstation delivers increasing levels of performance and preserves 100 percent binary compatibility with application software.

Sun Ultra 80 Workstations

The Sun Ultra 80 workstation is available in three configurations. Models 1450, 2450, and 4450 are configured with one, two, or four 450-MHz UltraSPARC-II processors respectively, with 4 MB of L2 cache. Models 1450 and 2450 are easily upgraded to their quad-processor counterparts by adding additional processors.

All three models include the PGX32 graphics or the highly integrated Sun Elite3D m6 graphics card, which provide a comprehensive range of graphics functionality and performance without the high cost of the large, expensive frame buffer through I/O bus technology provided by some of the competition.

Ultra 80 workstations continue the Sun tradition of delivering balanced system design and innovation. The powerful Ultra port architecture (UPA), introduced on the original Ultra systems, continues in the Ultra 80 system. The Ultra 80 workstation has dual UPA graphics slots to support up to two Sun Elite3D graphics-driven frame buffers.

The Ultra 80 workstation continues Sun's drive to deliver industry-standard PCI I/O bus, enabling access to hundreds of expansion and networking options. The Ultra 80 workstation PCI I/O bus with dual bus channels providing sustained high performance to the system's PCI slots. In addition, Sun has delivered the advanced 66-MHz PCI, which is capable of 200 MB per second throughput, ideal for high-performance networking requirements.

Product Family Placement

The Ultra 80 workstation is an advanced member of the current desktop product family, which scales from the low-cost, high-performance Ultra 5 and 10, to the two-way Ultra 60 workstation and up to the four-way Ultra 80 workstation.

Ultra systems have several things in common, including:

- The SPARC™ processor
- 100 percent binary compatible from the low end to the high end, including Sun's server family
- Scalable from the low-end uniprocessor systems to the 64-way Sun Enterprise™ 10000 (Starfire™) server
- Modular—easy-to-swap components

Workstation	Target Users
Ultra 5 and Ultra 10	<p>Designed as a low-cost desktop solution, the Ultra 5 and 10 systems appeal to customers looking for a low-priced system offering accelerated graphics, expandability, fast application performance, and investment protection. The Ultra 5 and 10 workstations are well suited for many different customers, from those who require low-cost imaging solutions to those who demand intensive graphics and expansion capabilities.</p> <p>Target markets include software development, financial, government, telecommunications, manufacturing, and education.</p>
Ultra 2	<p>Designed for the technical user who requires high performance and multiprocessing (MP) capability. MP-ready and multithreaded applications will benefit greatly from the performance of the Sun Ultra 2 system. The target customer is the traditional "power desktop" user who has performance, expansion, and SBus I/O requirements.</p>
Ultra 60 and Ultra 80	<p>The Ultra 80 workstation is a more advanced Ultra 60 workstation. Like the Ultra 60 system, the Ultra 80 workstation is designed for the technical user who requires high performance and multiprocessing (MP) capability. The Ultra 80 workstation also addresses the needs of graphics intensive users and supports up to two Sun Elite3D graphics accelerators. With the 450-MHz UltraSPARC-II processor with 4 MB of L2 cache, the Ultra 80 workstation is the performance leader for Sun's workstation family.</p> <p>The target customer is the traditional "power desktop" user who has performance and expansion requirements that exceed the capabilities of the Ultra 5 and Ultra 10 systems. This includes both technical and commercial users who need the large number of applications and the functional capabilities of the Solaris™ Operating Environment, the high performance of the UltraSPARC-II CPU, dual-headed graphics, and outstanding throughput.</p>



Key Messages

Sun Ultra 80 workstation is a relatively new member of the UltraSPARC processor-based desktop systems. UltraComputing™ technology has evolved to new levels of performance and technology innovation.

- **Innovative tower system design provides modularity for flexibility, maximum system growth, and expansion potential**
 - The Ultra 80 workstation offers the flexibility of starting with a single CPU and adding more CPUs later as compute needs grow
 - Memory capacity to 4 GB maximum (16 slots using existing 64-MB or 256-MB DIMMs)
 - Supports 18-GB drive options (supports 1.0-inch high, 3.5-inch, 10000-rpm UltraSCSI disk drives); up to 36-GB of drive space
 - Two UPA graphics slots able to support two Sun Elite3D m3 and/or Sun Elite3D m6 cards
 - Expanded front access capabilities: power switch, 5.25-inch removable media bay for options such as 32X CD-ROM or tape options; 3.5-inch front access bay for optional floppy drive or PCMCIA; and a third bay to accommodate either a 5.25-inch or 3.5-inch front access device
 - High I/O expansion with three full-sized and one short industry-standard PCI bus slots
- **High-performance UltraSPARC-II CPU processor module**
 - 64-bit SPARC™ version 9 at 450 MHz
 - 4 MB of second-level cache memory
 - 100 percent binary compatibility with current Solaris Operating Environment
 - Runs 32-bit applications unmodified from the Solaris 2.5.1, Solaris 2.6 and Solaris 7 Operating Environments
 - 64-bit applications supported on the Solaris 7 Operating Environment
- **Exceptional throughput**
 - UPA provides a crossbar-oriented interconnection establishing a 144-bit wide, ECC-protected data path to the CPU
 - Clocked at up to 112 MHz, the UPA crossbar gives a peak throughput of 1.8 GB per second (models with 450-MHz processor)
 - Memory subsystem offers a 576-bit-wide memory path
 - Architecture allows memory to be installed in fours to take advantage of 576-bit-wide memory path
 - UltraSCSI is integrated on the motherboard
 - A second UltraSCSI channel is available, allowing external devices to be connected to separately, further improving I/O throughput
- **One of the industry leaders for networking, connectivity, and I/O performance ratings**
 - 100 Mbps Fast Ethernet through twisted pair is a standard feature on all Ultra 80 workstations, but the system also maintains connectivity with 10 Mbps networking technology through an autosensing speed switch feature
 - Advanced networking options include FDDI and additional Fast Ethernet ports through industry-standard PCI option cards



- Innovative multiple-channel industry-standard PCI I/O bus provides sustained high throughput on all four full-sized PCI slots
- Industry's first 66-MHz PCI I/O slot capable of delivering 200 MB per second throughput ideal for high-performance networking requirements
- **Support for PGX32 PCI graphics provides fast X Window system performance, displaying 24-bit and 8-bit graphics at full speed**
 - With 8-MB of SGRAM, PGX32 graphics is capable of providing full 24-bit hardware double buffering at resolutions up to 1152 x 900, and 8+24-bit color up to 1280 x 1024, and support up to 1600 x 1280 in pseudocolor (8-bit color) mode
- **Support for high-power Sun Elite3D graphics family provides high-end graphics for a mid-range price**
 - Sun Elite3D m3 graphics is Sun's high-power, mid-range 3-D graphics option in the Elite graphics product line.
 - Sun Elite3D m6 graphics is Sun's high-power, high-end 3-D graphics option in the Elite graphics product line.

Sun Ultra 80 System Models

The Sun Ultra 80 workstation comes in three models that differ only in the installed processor module. Model 1450 is the entry Ultra 80 workstation. Model 2450 is the two-processor version of the Ultra 80 workstation. Model 4450 is the four-processor version of the Ultra 80 workstation and should be used in situations that require the highest computing performance.

Sun Ultra 80	Model 1450	Model 2450	Model 4450
Processor speed	1 x 450 MHz	2 x 450 MHz	4 x 450 MHz
UPA speed	112 MHz	112 MHz	112 MHz
Maximum Memory	4 GB	4 GB	4 GB
SPECint_95*	19.7	19.7	19.7
SPECfp_95*	27.9	36.1	44.6

* SPECint_95 and SPECfp_95 results using SPARCompiler™ version 5.0.

Availability

- Sun Ultra 80 workstation Models 1450, 2450, and 4450 began shipping November 1999.

Target Users

The Ultra 80 workstation is a more advanced Ultra 60 workstation. Like the Ultra 60 workstation, the Ultra 80 workstation is designed for the technical users who require high-performance and multiprocessing (MP) capability. Ultra 80 workstation also addresses the needs of users with graphics-intensive applications by supporting up to two Sun Elite3D m6 graphics frame buffers.

The target customer is the “power desktop” users who have performance, graphics and expansion requirements that exceed the capabilities of the Ultra 60 system. This includes both technical and commercial users who need the large number of applications and the functional capabilities of the Solaris Operating Environment, the high performance of the UltraSPARC-II CPU, dual-headed high-end graphics and outstanding throughput.

Target Markets

Industry	Key Features to Highlight
Electronic Design (EDA) <ul style="list-style-type: none"> • Chip designers, board designers • System houses • Telco 	<ul style="list-style-type: none"> • High-performance CPUs • High-memory capacity • Availability of applications
Financial <ul style="list-style-type: none"> • Stock and commodity traders • Banks 	<ul style="list-style-type: none"> • High performance • Compact design • Multimedia capabilities
Mechanical Design (MCAD/MCAE) <ul style="list-style-type: none"> • Automotive • Aerospace • Defense industry • Mechanical equipment designers 	<ul style="list-style-type: none"> • High-performance CPUs • High-end graphics performance and functionality standard • Availability of applications
Oil and Gas <ul style="list-style-type: none"> • 2-D, 3-D, and 4-D seismic analysis • Production engineering • Reservoir engineering 	<ul style="list-style-type: none"> • High-performance CPUs • Dual Sun Elite3D graphics monitors • Multithreaded OpenGL[®] platform • High-end performance and functionality for both graphics and imaging operations
Medical Imaging <ul style="list-style-type: none"> • Medical research 	<ul style="list-style-type: none"> • High-performance CPUs • Dual Sun Elite3D graphics monitors • Multithreaded OpenGL platform • High-end performance and functionality for both graphics and imaging operations
Research and Development <ul style="list-style-type: none"> • In-house development • Research institutions 	<ul style="list-style-type: none"> • High-computing performance • Feature-rich Solaris Operating Environment
Visualization and Simulation <ul style="list-style-type: none"> • Scientific visualization • Technical simulation 	<ul style="list-style-type: none"> • High-performance CPUs • High-end performance and functionality for both graphics and imaging operations • Dual Sun Elite3D graphics monitors



Selling Highlights

Alliances and Key Applications

Sun has worked closely with major software vendors to see that their applications are officially supported on the Sun Ultra™ 80 workstation. All major applications that are available can be found in our Sun Developer ConnectionSM catalog of third-party solutions.

Target Market	ISV— Software Applications	
Entertainment/ Animation/ Digital Creation	Adobe ArSciMed Electric Image Engineering Animation Inc. Lightwork NewTek Nichimen XaosTools	Photoshop Kinema/Sim Electric Image Vislab Kinetix (rendering tool kit) Lightwave 3D NWorld Pandemonium
EDA	Avant!/ISS Avant!/Meta Software Cadence Design Compass Design K2 Technologies Mentor Graphics Mentor/Precedence Silvaco SpeedSim Systems Science Viewlogic/Vantage Analysis Simplex Solutions Silvaco For general information see: http://www.sun.com/desktop http://www.dacafe.com:80/DACafe/	DRC/ERC product HSpice Vampire Dracula Pathfinder Mask Compose and Quick View Caliber ICVerify Checkmate Co-Simulation Backplane Simulators Atlas Athena Spice SpeedSim Vera SpeedWave MT Thunder and Lightning Fire and Ice Power Grid Virtual Wafer Fab Automation Tools
Health Care	Cemax Context Vision Geovision ISG Virtual Vision Software	VIP 2.0 (www.cemax-icon.com) Imaging processing for refining MR data Vision Silohet (www.isgtec.com)

Target Market	ISV— Software Applications	
MCAE	ANSYS, Inc. Computational Dynamics, Inc. ESI EXA Corporation Fluent, Inc. Fluid Dynamics, Inc. (FDI) Hibbitt, Karlsson & Sorensen, Inc. (HKS) Livermore Software Technology Corporation (LSTC) MacNeal-Schwendler (MSC) MARC Analysis Research Corp	ANSYS StarCD Pam-Crash Powerflow Fluent, Fluent UNS, Rampant, Nekton FIDAP ABAQUS LSDyna 3D PATRAN, NASTRAN Mentat, MARC For general information see: http://www.sun.com/desktop
Oil and Gas	AVS Cognesis GeoQuest Landmark Graphics Shell Oil	AVS Express, Toolmaster, AVS5 VoxelGeo GeoViz, Charisma ProMax, Seisworks, Strata Model, Earth Cube VolumeViewer

Compatibility

The Ultra 80 workstation runs Solaris™ 7 8/99 Operating Environment. It can also run 32-bit applications unmodified from the Solaris 2.5.1 Hardware 5/98 and Solaris 2.6 Hardware 11/97 Operating Environments, making these systems compatible with previous systems and software.

Market Value Propositions

- As a result of the multiprocessor capabilities of the Ultra 80 workstation, a company can use all the performance capabilities of Solaris Operating Environment software's multithreaded application base.
- As a result of the scalability and flexibility of the UltraSPARC™ processor architecture, a company can better protect its investment in hardware and software.
- As a result of Sun's memory and UPA, a company will notice the significant improvement in application performance and user productivity.
- As a result of the functionality and higher performance of Sun Elite3D graphics product families as well as the ability to use dual Sun Elite3D graphics frame buffers to display multiple graphics-intensive applications simultaneously, a company can be more productive and have shorter turn-around times while using interactive graphics applications.
- As a result of Sun's I/O networking, a company will be able to have faster networking throughput that will help increase application performance and user productivity.



Enabling Technologies

UltraSPARC™-II Processor

The Sun Ultra™ 80 workstation is a shared-memory, multitasking system built around the UltraSPARC™-II microprocessor. The UltraSPARC-II processor is Sun's latest generation of the SPARC™ processor family and the second generation of 64-bit UltraSPARC chips. The Ultra 80 workstation can use the 450-MHz UltraSPARC-II processor.

- Modules have the 64-bit SPARC V9 architecture.
- Systems have up to 4 MB of Ecache per CPU.
- As a member of the UltraSPARC family of CPUs, full binary compatibility is provided.

PCI Technology

System I/O for the Ultra 80 workstation is provided by two industry-standard peripheral component interconnect (PCI) data buses. All PCI buses in the Ultra 80 workstation comply with the 2.1 revision of the PCI specification, released in March 1995.

- Sun is an industry leader with PCI/66, which has twice the throughput of standard PCI.
- Two independent PCI buses deliver outstanding I/O bandwidth—sustained throughput of up to 200 MB per second.

PGX32™ PCI Graphics

PGX32™ graphics is targeted towards professionals requiring fast X Window system performance, displaying 24-bit and 8-bit graphics at full speed. With 8 MB of SGRAM, PGX32 graphics is capable of providing full 24-bit hardware double buffering at resolutions up to 1152 x 900, and 8+24-bit color put 1280 x 1024 and support up to 1600 x 1280 in psuedocolor (8-bit color) mode.

Sun Elite3D Graphics

Sun Elite3D graphics represents a high-powered graphics subsystem for the 3-D graphics market. Sun Elite3D graphics is combined with the visual instruction set (VIS™ software), a comprehensive set of imaging and graphics instructions built into a CPU. Sun Elite3D graphics comes in two models: Sun Elite3D m3 and Sun Elite3D m6 graphics.

Sun Elite3D graphics provides very fast, high-quality transformation and display of 3-D solid and wireframe objects, and dramatically accelerates high-end functionality, such as double-buffering, triangle and quad rendering, and lighting and shading. At the same time, Sun Elite3D graphics accelerates 2-D objects that meet X11 rules. Fast 8- and 24-bit window system and imaging performance are provided. Sun Elite3D systems provide 96-bit planes, including full 24-bit double-buffer planes required for smooth animation. A 28-bit Z-buffer is included to provide hardware assistance for hidden surface removal and dynamic rendering for 3-D objects.

Sun Elite3D systems utilize 3D-RAM technology. This technology is responsible for implementing fast, inexpensive 3-D frame buffers. In addition, Sun Elite3D graphics has three or six (depending on the model) on-board floating-point processors that speed up floating-point-intensive operations such as transformations, clip tests, face determinations, and lighting.

System Architecture

Technology Overview

Good performance through advanced applications typically demands excellent performance from more than one part of the system. Most often, an application consists of data fetching, computation, and presentation. Unless the system is designed to address all of these, it will always be limited by the weakest link in the chain.

The Sun Ultra™ 80 workstation is designed for balanced system performance, accelerating applications at every step. Faster I/O and networking, together with the Ultra port architecture (UPA) interconnect, allow fast data fetching. The UltraSPARC™ CPU provides supercomputing power, and moves data through the UPA at high speed. Tightly integrated Sun Elite3D graphics provides high-end graphics functionality and performance for the Ultra 80 Sun Elite3D systems.

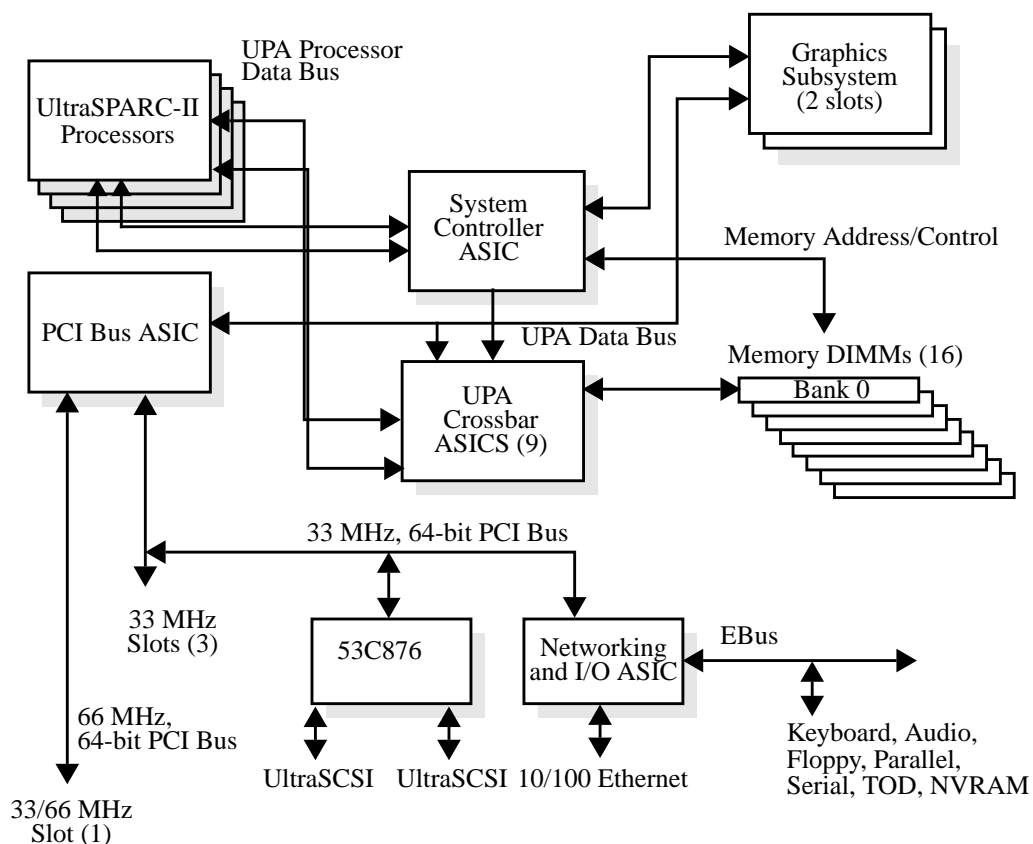

Figure 2. Architecture of the Ultra 80 system

The Sun Ultra 80 workstation has an integrated UPA. This is based on a packet-switched, crossbar architecture. Sun is the first manufacturer to provide such an architecture on the desktop. The Sun Ultra 80 workstation has nine buffered crossbar-switched processors that allow the memory and the graphics to interconnect. This architecture is the basis for high-powered computing and graphics.

Key Facts

Technical Fact Summary

- Sun's fastest performance uniprocessor and multi-processor Sun workstation; uses the 450-MHz UltraSPARC-II processor
- High-performance system bus provides fast access to memory and graphics
- Flexible hard disk expandability
 - Up to two internal 18.2-GB UltraSCSI disks
 - Up to 36-GB of total disk storage
- High-performance memory subsystem
 - Up to 4 GB for configurations using 16 x 256-MB DIMMs (installed in sets of four)
- Balanced system design
 - High performance UPA at 112 MHz or 1.8-GB-per-second throughput.
 - Matching performance enhancement in I/O, networking, and memory access
 - Two channels at 40-MB-per-second UltraSCSI
 - Innovative high-performance PCI I/O bus offering dual independent PCI buses, plus 66-MHz PCI support
 - Application performance without compromise
- High-end graphics functionality and performance at mid-level prices with Sun Elite3D graphics
- Designed for interactive media applications
 - Integrated visual instruction set (VIS™ software) in the UltraSPARC CPU
 - 8- and 24-bit PGX32™ PCI graphics option available
 - 32X CD-ROM, photo-CD compatible
- Expansion to advanced networking
 - Fast Ethernet, 100BASE-T, autosensing, and autoswitching to 10BASE-T for backward compatibility
 - PCI networking options include Gigabit Ethernet, ATM, token ring, and FDDI
- System enclosure
 - Cost-effective tower enclosure offers flexibility in expansion

UltraSPARC Processor

The Ultra 80 workstation is a high-performance, multiprocessing system built around the UltraSPARC-II microprocessor.

The UltraSPARC-II processors used in the Ultra 80 workstation are individually mounted on 4-inch by 6-inch, field-installable module cards along with associated UPA data buffers and up to 4 MB of high-speed SRAM external cache memory. These modules are the same as those used in the Ultra 60 workstation. This modular design facilitates easy system processor addition (to go from uniprocessor to multiprocessor configurations).

Features

- Integrated VIS instruction set software
- Multilevel trap handling
- CPU is mounted on field-installable module card with associated UPA data buffers and 4 MB of Ecache

Benefits

- Ready for increased performance on multimedia and networking operations
- Efficient process handling
- Facilitates easy system processor additions and system service

UPA System Bus

The Ultra 80 workstation processors, memory, and I/O subsystems are interconnected by the high-speed Ultra port architecture (UPA) crossbar datapath. This is an enhanced implementation of the same UPA design used in the Ultra 60 workstations. The CPU datapaths are 144 bits wide, with 128 bits for data and 16 bits for error correcting code (ECC). The UPA data path that support system I/O is 72 bits wide, with 64 bits for data and 8 bits for ECC. The memory interface supports a single 576-bit-wide data path.

With 450-MHz CPU installed, the UPA transfers data at 112 MHz, or one transfer every 9 nanoseconds. CPU segments, which transfer 16 bytes of data in parallel every clock cycle, each have a maximum transfer rate of 1.8 GB per second.

Features

- Single 576-bit-wide, high-speed memory bus
- 112-MHz UPA

Benefits

- High-performance memory access
- Flexibility in memory expansion options
- Able to use advanced UltraSPARC-II processors

Memory

The Ultra 80 workstation supports up to 4 GB of 60-ns, 5-volt, DRAM memory. Dual in-line memory modules (DIMMs) used by the Ultra 80 workstation are the same type as those used in the Ultra 60 workstations. Memory is organized into four banks of four DIMMs. DIMMs must be installed in sets of four identical DIMMs.

Features

- Uses the same 256-MB memory DIMMs as the Enterprise 450 servers as Ultra 60 workstations
- Supports 64-MB memory DIMMs

Benefits

- Helps protect customer's investment
- Provides flexibility in memory configurations



System I/O—High-Performance PCI Technology

System I/O for the Ultra 80 workstation is provided by two industry-standard peripheral component interconnect (PCI) data buses. Both PCI buses in Ultra 80 workstations comply with the 2.1 revision of the PCI specification, released in March 1995.

- PCI slot 1 operates at 33 or 66 MHz and supports either a 32-bit or 64-bit, 3.3-volt or universal PCI card.
- PCI slots 2 and 3 operate at 33 MHz and provide for 32- or 64-bit, 5-volt or universal PCI cards.
- PCI slot 4 operate at 33 MHz and provide for 32-bit 5-volt PCI cards.

Slots	Slot Width	Clock Rate	Card Input Voltages Supported
1	32 or 64 bits	33 or 66 MHz	3.3 volt or Universal
2-3	32 or 64 bits	33 MHz only	5 volt or Universal
4	32 bits	33 MHz only	5 volt or Universal

In addition to the I/O capabilities available through PCI option cards, the Ultra 80 workstation provides the following I/O channels directly from the main system board:

- Two internal/external 40-MB UltraSCSI channels with an external 68-pin SCSI connector
- One external 10/100BASE-T autoselect Ethernet port (supports either a Cat-5 UTP, or RJ45 connector)
- Two external EIA-232D or EIA-423 serial ports via two DB25 connectors (support EIA-423 synchronous data rates from 50 baud to 384 Kbps, and asynchronous data rates from 50 baud to 460.8 Kbaud)
- One external 2 MB per second, Centronics-compatible, bidirectional, parallel port with one DB25 connector
- One external standard Sun keyboard/mouse port (mini DIN-8 connector)

Features

- Industry's first 66-MHz PCI with 200-MB-per-second bandwidth (sustained)
- Two independent PCI buses
- Two independent UltraSCSI buses

Benefits

- High-performance I/O throughput
- Access to many third-party solutions
- High, sustained I/O throughput
- Higher performance throughput through the use of independent busses

Storage

Internal data storage for the Ultra 80 workstation is provided by up to two 3.5-inch UltraSCSI disk drives. UltraSCSI drive size is 18.2 GB. These 10000-rpm drives offer a peak data transfer rate of 40 MB per second.

In addition to its internal and external high-speed fixed storage capabilities, the Ultra 80 workstation provides an optional 32X CD-ROM drive and a 1.44-MB, 3.5-inch manual eject floppy drive for software installation and system management.

Features

- 40-MB-per-second UltraSCSI
- 18.2-GB disk options

Benefits

- Fast access and retrieval of mass storage data
- Flexibility in internal disk expansion and high internal capacity

The Ultra 80 workstation tower accommodates front-access peripheral expansion through one 1.6-inch drive half-height 5.25-inch bay for a CD-ROM or tape drive, one 3.5-inch bays for a diskette drive or PCMCIA adaptor or other options; and the third bay can accommodate either a 5.25-inch or 3.5-inch front accessible device.

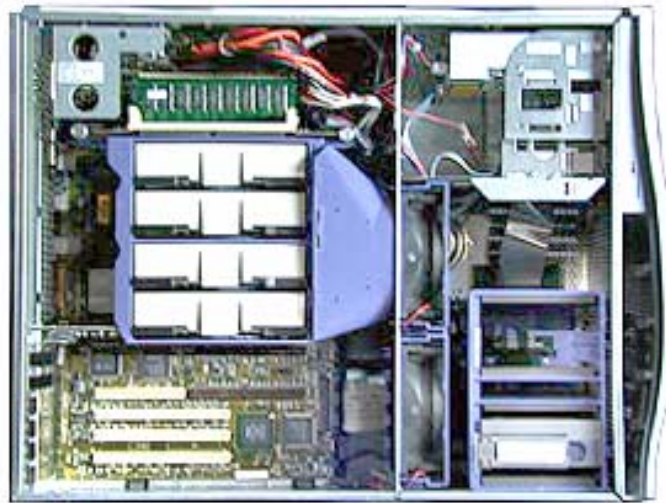

Figure 3. Ultra 80 workstation chassis with access panel removed

PGX32™ PCI-based Graphics

PGX32™ graphics is Sun's first high-resolution 8-bit and 24-bit color PCI graphics frame buffer supporting all Sun PCI I/O-based workstations and workgroup servers. The PGX32 graphics frame buffer is targeted towards professionals requiring fast X Window system performance, displaying 24-bit and 8-bit graphics at full speed. With 8 MB of SGRAM, the PGX32 graphics frame buffer is capable of providing full 24-bit hardware double buffering at resolutions up to 1152 x 900, 8+24-bit color up to 1280 x 1024 and support up to 1600 x 1200 in pseudo color (8-bit color) mode. PGX32 graphics supports the following resolutions:

Display Resolution	Color Mode	Double Buffered	Vertical Refresh Rate (Hz)
640 x 480	8-bit, 24-bit, 8+24-bit	Yes	60/72/75/85
800 x 600	8-bit, 24-bit, 8+24-bit	Yes	60/72/75/85
1024 x 768	8-bit, 24-bit, 8+24-bit	Yes	60/70/75/77/85
1024 x 800	8-bit, 24-bit, 8+24-bit	Yes	85
1152 x 900	8-bit, 24-bit, 8+24-bit	Yes	60/66/70/75/76
1152 x 900	8-bit	Yes	60/66/70/75/76/85
1280 x 800	8-bit, 8+24-bit	Single Only	76
1280 x 1024	8-bit	Yes	60/67/75/76/85
1280 x 1024	24-bit, 8+24-bit	Single Only	60/67/75/76
1600 x 1000	8-bit	Yes	66/76
1600 x 1200	8-bit	Yes	60/65/66/70/75/76/80

The PGX32 graphics frame buffer supports all standard Sun video timings and also supports VESA timings for PC type displays and flat panels. It is also capable of supporting Sun's 24-inch display @ 1600 x 1000.

The PGX32 graphics frame buffer can work in single or multiheaded configurations. It can be set as the only frame buffer in the system as the console or as the secondary frame buffer. Up to four PGX32 graphics frame buffers are supported in any system.

Features

- Simultaneous 8-bit and 24-bit
- 24-bit true color video support
- Support for high resolutions
- PCI 33-MHz format
- 1280 x 1024 at 76-Hz resolution

Benefits

- Eliminates colormap flashing display visual support when running both 8-bit and 24-bit applications; allows legacy 8-bit applications to run while simultaneously running the latest 24-bit applications
- Display the high quality color on screen
- Ability to display more information with higher quality and image detail
- Allows usage in the widest variety of systems from the Ultra 5 up to the Sun Enterprise™ 450 workgroup server
- High-resolution display quality standard

Features

- Multiheaded (display) support; multiple frame buffers (with support for up to four PGX32 frame buffers in one system)
- 8-bit overlay plane

Benefits

- For users who must do multiple tasks simultaneously, for example, command and control applications, design, and analysis for engineers
- Allows overlay of 8-bit windows on top of the 24-bit visuals without damaging the underlying visual, resulting in seamless integration and manipulation of windows

Sun Elite3D Graphics Overview

Sun Elite3D graphics greatly accelerates the rendering of 3-D triangles, vectors, and texture maps over what is possible with a raw CPU. It does this by adding specialized graphics floating-point units and more powerful pixel-drawing chips. It supports a 1280 x 1024 96-bit-deep frame buffer. The 96-bit pixels support two 24-bit color buffers, an 8-bit pseudo-color overlay buffer and a 28-bit Z-buffer, plus some miscellaneous control planes.

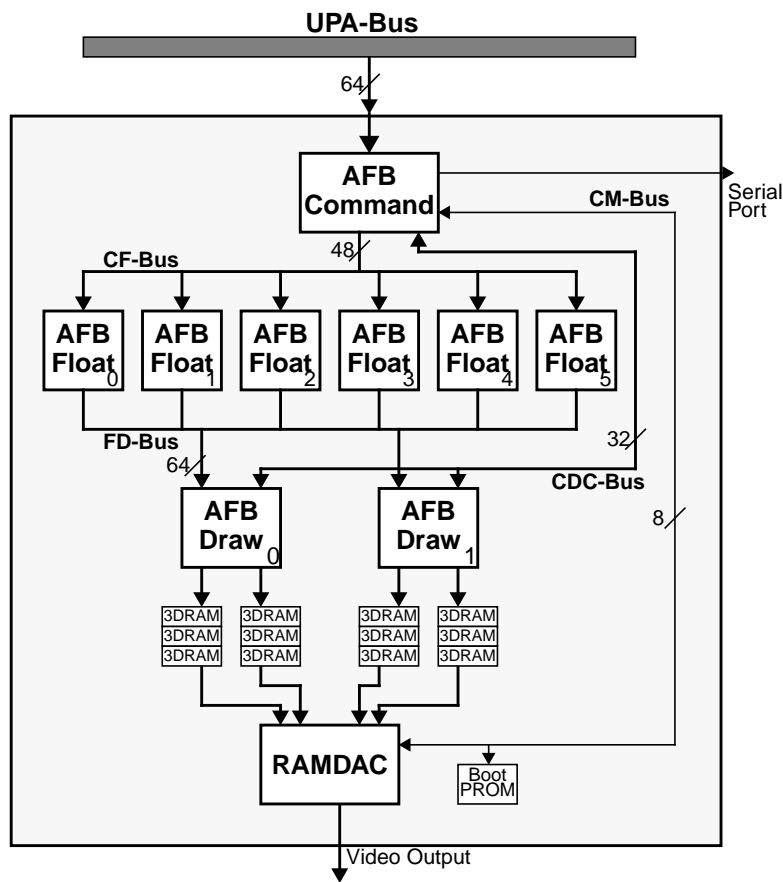

Figure 4. Sun Elite3D m6 graphics chip-level diagram

Sun Elite3D graphics has a highly parallel and efficient graphics pipeline. The Sun Elite3D graphics architecture uses a new generation of 3D-RAM chip. This chip speeds up a read/modify/write pixel access from 160 ns to 10 ns, changing all of the rules about graphics pipeline behavior.



AFB-Command, at the interface level, has functionality which supports rendering of model space geometry. The main change is to allow the most important bits to be packaged up into single-header words that can be passed down with the geometric data without stopping the pipeline. Additional functionality includes complete binary compatibility with the register set and functions, as well as support for the OpenGL[®] platform.

Given the technological changes brought on by 3D-RAM, the primary justification for the existence of a 3-D graphics accelerator is to deliver an order of magnitude more floating-point performance than a contemporary general purpose RISC CPU, at a price less than that of a single CPU and cache.

Sun Elite3D Graphics Features and Benefits

Features

- Integrated imaging
- High-performance accelerated 24-bit double-buffered 3-D graphics
- 28-bit Z-buffer
- 8-bit overlay plane
- Gouraud shading
- Alpha blending and screen-door transparency
- Line and dot antialiasing
- Per-pixel depth cueing
- Per-pixel alpha interpolation
- 4-bit stencil support with hardware acceleration of OpenGL stencil functions
- Accelerated lighting
- Compressed geometric decompression
- Four 8-bit color maps
- Adjustable gamma correction
- NTSC/PAL video timing support

Benefits

- Performs fast imaging and 3-D on unified frame buffer
- Smooth animation and interactivity of 3-D graphics
- Improves visual quality and depth accuracy
- Allows overlay of 8-bit windows on top of the 24-bit visuals without damaging the underlying visual; allows seamless integration and manipulation of windows
- Allows smooth shading of solid geometry
- Simulates transparent materials such as glass
- Needed in MCAD and visualization for better visual quality
- More accurate depth cueing or fog
- Greater accuracy and image quality
- Provides greater performance
- More lights can be turned on for enhanced visual display without encountering large performance penalties
- Allows much more geometric data to be stored in the available memory, but also reduces bus bandwidth needs as well; for efficient geometry handling to enable network-centric graphics collaboration
- For dynamic colormap segment allocation when running 8-bit window systems should eliminate color flashing problems
- Allows users to gamma correct visuals for enhanced visual quality
- Supports frame buffer to video output

Features

- Stereo video output (960 x 680 at 112 Hz) supported with 19- and 21-inch monitors
- 1280 x 1024 at 76-Hz resolution standard
- Dual-headed support (two Sun Elite3D m6 frame buffers)
- OpenGL 1.1.2., XGL™ 3.0, XIL™, X Windows, and Java 3D™ API support
- Binary compatibility with Creator Graphics product family

Benefits

- With frame buffer, monitor, and window systems support for stereo, users can get more accurate representation of 3-D data
- High-resolution display quality
- For users who need to do multiple things simultaneously, i.e., command and control applications, 3-D, and video playback for animators, design and analysis for engineers
- A choice of APIs
- Interoperability with existing applications and users

Sun Ultra 80 Workstation Graphics Performance

Benchmarks	Ultra 80 PGX32	Ultra 80 Sun Elite3D m3	Ultra 80 Sun Elite3D m6
Xmark	12.1	39.2	40.5
2-D Vectors per Second	897K	5.0M	5.0M
3-D Performance			
• 3-D vectors/second	521M	4.9M	8.8M
• 3-D mesh/second	—	3.0M	5.9M
• 3-D quads/second	—	1.5M	1.3M
GPC PLB			
• PLBwire93	28.1	301	433
• PLBsurf93	—	519	680
OpenGL			
• ProCDRS-02	—	13.8	19.1
• DX-05	—	25.2	28.7
Standard Color Monitors Supported	17, 19, and 21 inch 18-inch flat panel	17, 19, and 21 inch 18-inch flat panel	17, 19, and 21 inch 18-inch flat panel

Note: Configuration for timing includes the Solaris™ 7 Operating Environment and OpenGL 1.1.2 performance data collected in September 1999. Performance data is subject to change. Please see Sun's web site at <http://www.sun.com/desktop/> for latest performance numbers.

Metrics defined:

- 2-D vectors are 10 pixels long, X11 perf numbers
- 3-D vectors are 10 pixels long, depth cued, clip tested, perspective projection, solid line through OGL
- 3-D triangles: 25 pixel triangle mesh, one light source
- 3-D quads: 100 pixel, independent quadrilaterals, with one directional light source
- Both 3-D mesh and quads are Gouraud shaded, randomly oriented, transformed, clip tested, with perspective projection and Z-buffered via OGL

Special features

- Accelerated imaging and advanced 3-D graphics with Gouraud shading, line antialiasing, per-pixel depth cueing, subpixel addressing, transparency, stereo viewing with monitor.
- Sun Elite3D graphics utilize a new connector for stereo viewing synchronization, a 7-pin mini-DIN style of connector. (StereoGraphics Corporations sells a cable adapter for connecting the old and new styles of connectors. It can be ordered from them using the part number ESUN.)



Sun Ultra 80 System Configuration

	Sun Ultra 80 Model 1450	Sun Ultra 80 Model 2450	Sun Ultra 80 Model 4450
Dimensions	44.5 cm x 25.5 cm x 60.2 cm (H x W x D) 17.5 inches x 10.0 inches x 23.7 inches		
Weight	29.5 kg (65 pounds)		
CPU and UPA			
• Architecture	UltraSPARC-II		
• Clock rate	450 MHz		
• Processor slots	4		
• Cache on chip	32 KB		
• External cache	4 MB		
• UPA speed	112 MHz		
Memory			
• Memory type	ECC		
• Number of slots	16		
• Capacity	256 MB to 4 GB		
• DRAM speed	60 ns		
• Bus width	576 bits		
• DIMM sizes	64 and 256 MB		
Internal Storage	Two internal disk with 18.2 GB capacity each = 36 GB total		
I/O Interfaces			
• UltraSCSI	40 MB/sec. UltraSCSI (SCSI-3), 2 channels		
• Serial ports	Two RS-232C/RS423 DB25		
• Parallel port	Centronics compatible (DB25)		
• PCI I/O bus	Three full-size and one half-size PCI slots (version 2.1): Three at 33 MHz; one at 33 or 66 MHz		
Monitor and Graphics Support			
• Graphics supported in PCI slots	Up to four PGX32 graphics cards		
• Graphics supported in UPA slot	Two Sun Elite3D m3 frame buffer and/or Sun Elite3D m6 frame buffer		
• Monitors	17, 19, and 21 inch color monitor; 18-inch flat panel		
Networking Ports	TP Ethernet 10/100BASE-T		

	Sun Ultra 80 Model 1450	Sun Ultra 80 Model 2450	Sun Ultra 80 Model 4450
Backup and Distribution			
• Floppy	Optional 3.5-inch floppy		
• CD-ROM	SunCD™ 64 MB		
• Internal	Optional 12 to 24-GB DDS-2 4-mm, 14-GB 8-mm		
• External	2.1 to 18.2-GB Sun StorEdge™ UniPack systems 8.4 to 109.2-GB Sun StorEdge MultiPack systems 4- to 8-GB SLR tape 20 to 40 GB, 8-mm 12 to 24-GB, 4-mm DDS-3 72 to 144-GB, 4-mm DDS-3 autoloader 400-GB Sun StorEdge L400 tape library 20 to 40-GB DLT 4000 35 to 70-GB DLT 7000		
Solaris Operating Environment Support	Solaris 2.5.1 Hardware: 11/97 Solaris 2.6 Hardware: 5/98 Solaris 7 Hardware: 8/99		

System Management

System Administration

Sun Ultra™ 80 workstations deliver the power and graphics needed by the customers who use heavy compute-intensive applications. Customers who run these compute-intensive applications require a system like the Solaris™ Operating Environment software that can provide highly reliable, available, fast and safe desktop computing environment. Built into Solaris 7 Operating Environment are systems management and security features that will help deliver the computing environment demanded by these customers. Sun also offers unbundled systems management products that will supplement the systems management features in Solaris 7 Operating Environment. Together, the Solaris 7 Operating Environment management features and Sun's unbundled systems management products create one of the most stable and available desktop computing environment in the industry.

Solstice AdminTools™ Software

Solstice AdminTools™ software is a set of GUI-based administration tools that have been shipping since Solaris 2.2 Operating Environment, and can be used to provide local systems administration. Solstice AdminTools software can be used to manage user accounts, groups, hosts, printers, serial ports, and installation/removal of software.

SunVTS™ Software

The SunVTS™ system exerciser is a graphically oriented UNIX® application that permits the continuous exercising of system resources and internal and external peripheral equipment. Used to determine if the system is functioning properly, SunVTS software incorporates a multifunctional stress test of the system through operating-system-level calls, and allows the addition of new tests as they become available.

Solaris™ Web Start Software

Solaris™ Web Start software is an easy-to-use Java™ application that guides users through the installation of both the Solaris Operating Environment and copackaged application software with a single on-screen button. Its graphical user interface facilitates file system configuration. It also features a built-in suite of on-line information and answers questions about the product itself, the software it installs, and the hardware platform it supports.

Solstice Enterprise Agents™ Software

Solstice Enterprise Agents™ software allow the workstation to be managed from simple network management protocol (SNMP)-based system/network management tools. Solstice Enterprise Agents software is based on the new extensible agent technology or manager/subagent technology. The manager agents receive and respond to SNMP or desktop management interface (DMI) requests. After retrieving the appropriate values from the respective subagents, responses are sent. The subagents manage information bases (MIBs or MIFs) designed for specific components and applications.

Solaris Desktop Extensions Software

Solaris Desktop Extensions (SDE) software features ideal systems management tools for those non-UNIX users who want to quickly view processes and system resources. The process manager in SDE software is a GUI-based tool that enables users to quickly identify, sort, suspend, and eliminate processes based on attributes such as CPU consumption and time elapsed.



SDE software also features a GUI-based performance monitor, enabling users to quickly monitor some of the key system resources such as CPU, load, disk, page, context, job swaps, interrupts, packets, collisions, and errors.

ShowMe How™ Software: State of the Art Installation and Maintenance Instruction

ShowMe How™ software is a documentation system that presents information in a highly understandable multimedia format. Installation and service tutorials as well as reference information provide users with comprehensive, easy-to-use instruction. ShowMe How software streamlines installation and maintenance to help lower service costs and maximize system uptime. Some of the features of this tool are:

- Distributed on CD-ROM
- Movies of installation and replacement procedures played through ShowMe TV™ software packaged with application
- Photo sequences with narrated installation and replacement procedures
- Text-based instructions can be viewed on-line and printed, excerpted from standard Sun documentation
- Photos with active callouts link to more detailed photos and text-based reference information

Solaris Operating Environment Software

Sun workstations are supported by Solaris 7, one of the industry's leading enterprise operating environments. The Solaris 7 Operating Environment contains the base-level functionality required for all Sun Workstation™ systems. The Solaris 7 Operating Environment is a solid, scalable 32-bit and 64-bit operating environment. The Solaris 7 Operating Environment includes:

- A 32- and 64-bit kernel
- Standards-based networking with easy access to a wide range of computing environments and network technologies
- Platform support for both SPARC™ and Intel
- Integrated Java technology
- System administration support

The Solaris Operating Environment delivers a competitive advantage to businesses through networked computing, scalability, and multiarchitecture support. The Solaris Operating Environment provides an advanced, outstanding solution for all customer IT needs, both technical and business. With its strength in enterprise-class reliability, scalability, and performance, the Solaris Operating Environment is an industrial-grade solution with the quality and robustness required to deliver mission-critical computing.

Sun Ultra 80 systems are supported by Solaris 2.5.1 Hardware: 11/97, Solaris 2.6 Hardware: 5/98, and Solaris 7 Hardware: 8/99 Operating Environments.

Solaris Features and Benefits

Features

- Mainframe-class reliability, availability, and serviceability
- Higher performance
- Improved scalability
- Greater ease of use
- Comprehensive global product
- 100 percent binary compatibility

Benefits

- Provides greater system stability and less system downtime by allowing customers to add, remove, and replace defective hardware without rebooting the system
- A complete 64-bit computing environment provides greater computing capacity, precision, and performance
- The 64-bit kernel provides access to and capacity for more system resources; this allows more applications to be consolidated onto a single server, and enables systems to handle much larger problem sets
- Web-based installation, text and voice notes, and graphical process manager make Solaris Operating Environment easy to install and use
- Supports the euro currency symbol, complex text formats for Arabic, Thai, and Hebrew languages, and the development of multilingual applications
- Software investment protection—all of today's Solaris-certified 32-bit applications continue to run on Solaris 7 Operating Environment with out modification

Solaris 7 Operating Environment 11/99 New Features

A number of new features were added to the Solaris 7 Operating Environment in November 1999. They are:

- **Netscape™ application launcher**—allows users to easily access and launch Netscape files and associated Netscape applications such as Composer automatically. This new Netscape application launcher virtually eliminates the need to run the entire Netscape environment, making access to Netscape applications simpler than ever.
- **PDASync (Personal Digital Assistant) support**—a Java technology-based application for professionals on the go. Enables users to easily synchronize their desktop calendar, mail, address book, and memos with their PDA.
- **X11R6.4 support**—a new enhanced version of XServer delivers key new features that increase user productivity and mobility. These are:
 - **Web-enabled X application**—access on any browser-based desktop. Provides access to corporate X applications for remote users through the Internet or intranet
 - **Xinerama support**—provides one logical screen image support that can be displayed across multiple monitors
 - **Color utilization policy (CUP) support**—minimizes color-map flashing
 - **XPrint extension** —provides a framework for X applications to render on non-display devices, such as printers and facsimile machines
 - **EnergyStar support**—built-in power management controls to conserve workstation power
 - **Developer toolkit**—includes new public APIs and documentation for Xinerama, XPrint, XKB, DPMS, and CUP extensions



Solaris 7 Operating Environment 5/99 New Features

PC Launcher 1.0 (SPARC only) was added to the Solaris 7 Operating Environment in May 1999. PC Launcher allows the SunPCi™ card to have seamless access and power to view, edit, and print many popular types of PC files or attachments instantly, by automatically launching the associated Windows application. By incorporating PC launcher into the Solaris CDE desktop, users can share attachments and files created by Microsoft Word, Excel, PowerPoint, Lotus 1-2-3, and AutoCAD applications.

Graphics Software Interfaces

Sun systems support all Solaris 2.5.1, Solaris 2.6, and Solaris 7 Operating Environment graphics and window system APIs, including OpenGL®, XGL™, XIL™, and Display PostScript™ APIs. A large number of Sun and third-party graphics APIs are also supported, including IRIS GL, OpenGL, GKS, HOOPS, Java 3D™, and PHIGS. Industry-standard X-extension libraries, such as Xlib and PEXlib, are available and are accelerated via the XGL and XIL foundation graphics libraries.

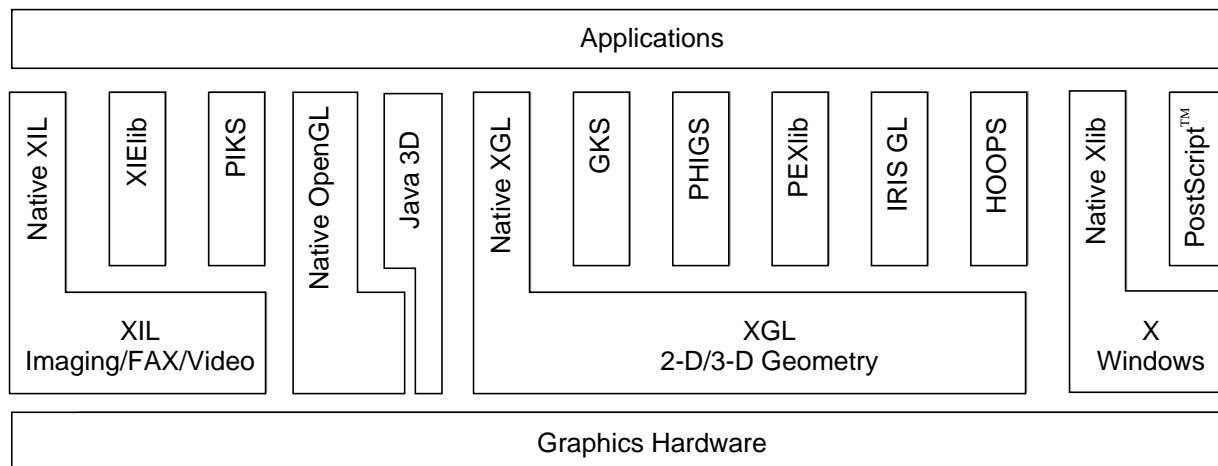

Figure 5. Graphics software interfaces

Solaris Operating Environment System Requirements

Disk Space	End user: 25 MB Developer: 40 MB (runtime binaries and header files)
Memory	64 MB minimum 128 MB or higher recommended for serious applications

Solaris Operating Environment Licensing and Usage

All Sun system and system-board products include a Solaris Operating Environment license. The type of Solaris license(s) shipped with each platform reflects the way in which that system is most commonly used. Additional Solaris licenses are available to allow increased usage of the software.

Ultra 80 workstations come with a Solaris Desktop license. This license is limited and does not provide several of the services provided by the Solaris Server license, such as:

- Allowing more than two users to be directly connected
- Providing database or compute services for more than two continuous users
- Providing swap-disk space for any other system
- Providing home-directory space for any other system



If a system shipped with a Solaris Desktop license will be used as a server (requires services listed above), the system must be upgraded to a Solaris Server license.

OpenGL 1.1.2 API for Solaris Operating Environment

The OpenGL API for the Solaris Operating Environment provides a complete solution for developing and deploying interactive 3-D applications across SPARC workstations. It enables mainstream, industry-leading 3-D graphics and visualization applications to be deployed on Sun's Ultra family of graphics workstations at a compelling price-to-performance ratio. OpenGL API is an application programming interface (API) that provides 2-D and 3-D graphics functions, including modeling, transformations, color, lighting, and smooth shading, as well as advanced features such as texture mapping, NURBS, fog, alpha blending, and motion blur. The OpenGL API works in both immediate and non-editable display-list graphics modes.

The OpenGL API is targeted at developers creating interactive 3-D applications for the enterprise, the intranet, and the Internet. These developers are affiliated with ISVs or VEUs in technical markets or in research labs. Potential users include those in computer-aided design and manufacturing, global information systems, simulation, industrial design and modeling, entertainment, biochemistry, and petroleum exploration market segments.

Widespread multivendor availability of the OpenGL API allows source-code portability of 3-D graphics clients. OpenGL 1.1.2 for the Solaris Operating Environment is a compliant implementation of OpenGL 1.1 from the OpenGL Architecture Review Board (ARB) and is, therefore, source-code compatible with other conformant OpenGL applications on the market. Most existing OpenGL applications just need to be recompiled in order to run with the OpenGL 1.1.2 API for the Solaris Operating Environment.

The OpenGL 1.1.2 API for the Solaris Operating Environment is available for the Creator, and Sun Elite3D graphics product families, where the OpenGL functionality is accelerated in hardware. In addition, it is available on all the legacy SPARCstation™ systems equipped with SX, ZX, GX, GXplus, TurboGX™, TurboGXplus™, S24™, PGX™, or FSV frame buffers, which is made possible through an optimized software-rendering pipeline.

OpenGL 1.1.2 API Features and Benefits

The OpenGL 1.1.2 API provides the following features:

Features

- 64-bit OpenGL libraries
- Occlusion culling test extension
- Improvements in DPA rendering support
- Constant texture data extension
- General performance improvements

Benefits

- Allows OpenGL applications to take advantage of the full 64-bit addressing in Solaris 7 Operating Environment
- Enables applications to trivially reject occluded objects in a scene, resulting in big improvements in interactive rendering performance for visualization of large models
- Enables OpenGL rendering on Ultra 80 systems using the PGX or PGX24™ graphics frame buffers
- Helps reduce texture mapping memory utilization and loading time
- Enables better performance for all supported graphics cards; in particular, there has been some substantial performance gains for Sun Elite3D frame buffers—for some applications over 100 percent

OpenGL 1.1.2 API Tech Facts

OpenGL 1.1.2 API system requirements:

Platforms	Sun Elite3D, Sun Creator3D, Creator, PGX, ZX, GX, TGX, SX product families
<ul style="list-style-type: none">• Operating Environments supported	Solaris 2.5.1 Maintenance Update 3 Solaris 2.6 or higher Solaris 7
<ul style="list-style-type: none">• Window system supported	CDE or OpenWindows™
Disk space	
<ul style="list-style-type: none">• For end-user runtimes	32 MB for 32-bit 55 MB for 64-bit
<ul style="list-style-type: none">• For developers	
<ul style="list-style-type: none"><ul style="list-style-type: none">– Runtime binaries and header files	44 MB for 32-bit 67 MB for 64-bit
<ul style="list-style-type: none"><ul style="list-style-type: none">– To build example files	54 MB for 32-bit 77 MB for 64-bit
Memory	64 MB minimum 128 MB or more recommended

Ordering Information

The Sun Ultra™ systems use a marketing part number scheme that is designed to provide greater flexibility and expandability. This page explains how to read the part numbering scheme. “N” means “Not available” or “Not applicable.”

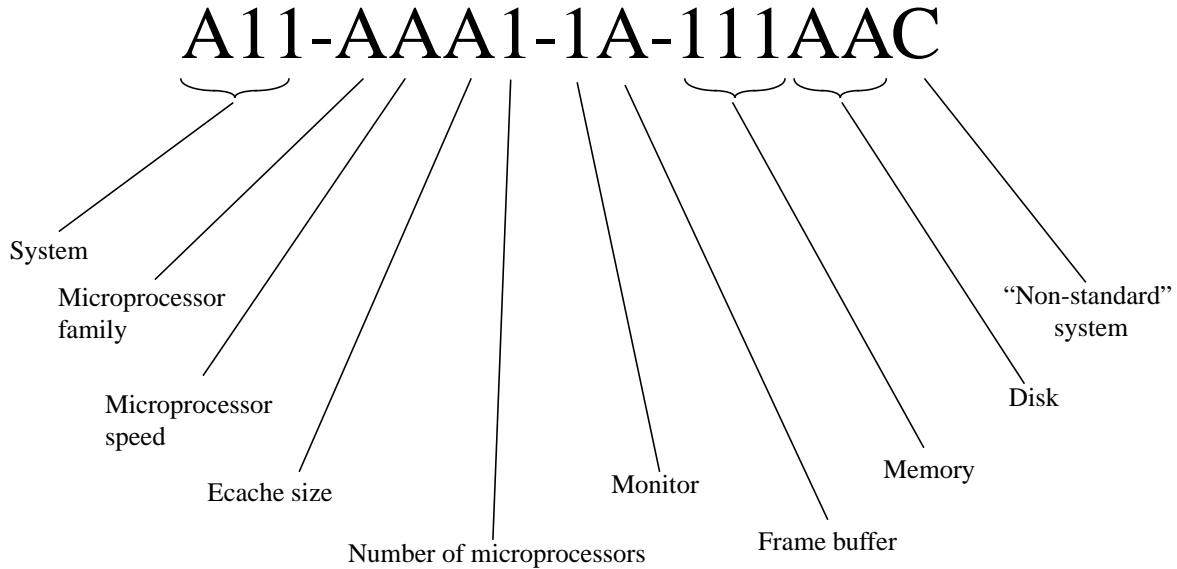

(Note: A = alpha character, 1 = numeric character, C = optional alpha or numeric character)

Model Key (Subset of Part Number Definitions)

System A27 = Sun Ultra 80	Ecache Size D = 4 MB	Frame Buffer T= PGX32™ M = Sun Elite3D m6	Disk AQ = 18.2 GB NN = Diskless
Microprocessor Family U = UltraSPARC™	Monitor 9 = No monitor configured	Memory 1024 = 1 GB 256 = 256 MB	Non-standard O = OEM R = Master Reseller V = Switzerland/Denmark
Microprocessor Speed L= UltraSPARC-II 450 MHz			

Sun Ultra 80 Workstation Model 1450

Part Number	System
	One 450-MHz UltraSPARC-II processor with 4-MB Ecache
A27-ULD1-9T-256AQ	– 256-MB DRAM, PGX32 PCI graphics, 18.2-GB, 10000-rpm internal UltraSCSI hard drive, no monitor
A27-ULD1-9T-1024AQ	– 1-GB DRAM, PGX32 PCI graphics, 18.2-GB, 10000-rpm internal UltraSCSI hard drive, no monitor
A27-ULD1-9M-1024AQ	– 1-GB DRAM, Sun Elite3D m6 graphics, 18.2-GB, 10000-rpm internal UltraSCSI hard drive, no monitor

Sun Ultra 80 Workstation Model 2450

Part Number	System
	Two 450-MHz UltraSPARC-II processors with 4-MB Ecache
A27-ULD2-9T-1024AQ	– 1-GB DRAM, PGX32 PCI graphics, 18.2-GB, 10000-rpm internal UltraSCSI hard drive, no monitor
A27-ULD2-9M-1024AQ	– 1-GB DRAM, Sun Elite3D m6 graphics, 18.2-GB, 10000-rpm internal UltraSCSI hard drive, no monitor

Sun Ultra 80 Workstation Model 4450

Part Number	System
	Four 450-MHz UltraSPARC-II processors with 4-MB Ecache
A27-ULD4-9T-1024AQ	– 1-GB DRAM, PGX32 PCI graphics, 18.2-GB, 10000-rpm internal UltraSCSI hard drive, no monitor
A27-ULD4-9M-1024AQ	– 1-GB DRAM, Sun Elite3D m6 graphics, 18.2-GB, 10000-rpm internal UltraSCSI hard drive, no monitor

Ordering Guidelines and Notes

- **Memory**

- The Ultra 80 workstation supports 4 GB of main memory. This architecture currently accepts 64- and 256-MB memory modules. The 256-MB DIMMs are of the same type as those used in the Sun Enterprise™ 450 systems.
- The Ultra 80 workstation can accommodate up to 16 DIMM modules in increments of four. DIMM modules within each set *must* be of the same type. DIMM module sets of four may be mixed.
- The 64-MB DIMMs for the Ultra 80 workstation (X7043A) can be used in the Ultra 60 workstation. However, the existing 64-MB DIMMs used in the Ultra 60 workstation (X7003A) are not supported in Ultra 80 systems.

- **Graphics**

- The Ultra 80 workstation supports the PGX32 PCI graphics for non-3D applications.
- The Ultra 80 workstation has two UPA graphics slots that support the Sun Elite3D m3 and Sun Elite3D m6 graphics accelerators. A customer can mix and match any of these accelerators within the Ultra 80 workstation.

- **Monitors**

- Monitors are not included with any Ultra 80 systems.
- A monitor must be purchased with an Ultra 80 workstation.
- The customer can choose among the 17-, 19-, and 21-inch color monitor, or the 18-inch flat-panel display.

- **SCSI**

- The internal SCSI host controller operates in Fast-20 (UltraSCSI) mode by default. Installation of non-FAST-20 devices, although allowed, will decrease overall SCSI performance.
- The total combined SCSI cable length must not exceed three meters for Fast/Wide operation or 1.5 meters for Fast-20 (UltraSCSI) operation.
- To enable Fast-20 speeds on all devices on the bus, it is recommended that:
 - A maximum of two Sun StorEdge™ UniPack systems using Fast-20 cables be connected to the external connector.
 - All devices on the SCSI bus should be Fast-20 devices. (Non-Fast-20 devices may cause the internal devices to run at Fast/Wide speeds, but are supported.)

- **Keyboard**

- Type 6 keyboards are supported on the Ultra 80 workstation.

Options

Below is a comprehensive list of system expansion, networking, graphics, and multimedia options that are supported by Sun Ultra 80 systems. Refer to the Sun Price Book and configuration guides for currently available option listings, configuration notes, and ordering information. When no maximum number is listed, refer to ordering or configuration notes for that option.

Part Number	Option Description	Maximum Number Supported	Comments
Processors			
X1195A	UltraSPARC-II 450 MHz, 4-MB Level 2 cache	4	
Memory			
X7043A	128-MB, 60-ns DIMM memory expansion (2 x 64 MB)	8	These are all pairs of DIMM units
X7005A	512-MB, 60-ns DIMM memory expansion (2 x 256 MB)	8	
Mass Storage—Internal			
X5237A	18.2-GB, 10000-rpm Fast/Wide UltraSCSI disk, 1-inch high	2	
Mass Storage—Removable Media			
X6004A	3.5-inch, 1.44-MB manual-eject floppy drive (triple density)	1	
X6166A	SunCD™ 32X CD-ROM drive with cable (for FlexiPack)	1	
X6106A	4-GB to 8-GB SLR tape drive	1	
X6208A	7-GB, 8-mm 8505XLtape drive	1	
X6213A	7-GB, 8-mm 8705DX tape drive	1	
X6212A	7-GB to 14-GB, 8-mm tape drive	1	
X6256A	4-GB to 8-GB 4-mm DDS-2 tape drive	1	
X6282A	12-GB to 24-GB, 4-mm DDS-3 tape drive	1	

Part Number	Option Description	Maximum Number Supported	Comments
Mass Storage—External			
X814A	5.0-GB, 8-mm tape backup drive, desktop storage module	2	
X827A	20-GB, 4-mm tape autoloader, desktop storage module	2	
X567A	2.1-GB Fast SCSI-2 desktop disk pack	4	
X737A	2.1-GB Fast SCSI-2 desktop disk pack	4	
X579A	SunCD 2Plus™, desktop storage pack	2	
X660A	150-MB QIC tape drive, desktop storage pack	2	
X822A	5.0-GB, 4-mm tape drive, desktop storage pack	2	
X834A	10-GB, 8-mm backup tape drive, desktop storage module	2	
X844A	14.0-GB, 8-mm tape drive, desktop storage pack	2	
Mass Storage—Sun StorEdge UniPack			
	<i>The following UniPack options come with a 68–68 pin SCSI cable:</i>		
SG-XDSK010A-4G	4.2-GB, 7200-rpm UniPack	16	NOTE: Order X3856A 68-pin to 68-pin SCSI cable with power cord for connecting a Sun StorEdge UniPack, FlexiPack, or MultiPack to Ultra 80 systems
SG-XDSK010A-9G	9.1-GB, 7200-rpm UniPack	16	
SG-XDSK010B-18G	18.2-GB, 7200-rpm UniPack	16	
SG-XDSK010B-36G	36.4-GB, 7200-rpm UniPack	16	
SG-XTAPMLR-310A	25-GB to 50-GB MLR tape drive in UniPack desktop enclosure	2	
SG-XTAPSLR-010A	4-GB to 8-GB SLR tape drive UniPack	2	
SG-XTAP4MM-010A	4-GB to 8-GB, 4-mm DDS-3 tape drive in UniPack desktop enclosure	2	
SG-XTAP4MM-011A	12-GB to 24-GB, 4-mm DDS-3 tape drive in UniPack desktop enclosure	2	
SG-XTAP8MM-010A	7-GB to 14-GB, 8-mm drive in UniPack desktop enclosure	2	
SG-XTAP8MM-011A	20-GB to 40-GB, 8-mm drive in UniPack desktop enclosure	2	
X5101A	1.05-GB, 7200-rpm Fast/Wide SCSI-2 disk UniPack	4	
X5151A	2.1-GB, 7200-rpm Fast/Wide SCSI-2 disk UniPack	4	
X5209A	4.2-GB, 7200-rpm Fast/Wide SCSI-2 disk UniPack	4	
X5253A	9.1-GB, 7200-rpm Fast/Wide SCSI-2 disk UniPack	4	
X6101A	2.5-GB QIC tape UniPack	1	
X6108A	4-GB to 8-GB, SLR tape drive UniPack	1	
X6151A	SunCD 4X CD-ROM UniPack	1	
X6157A	SunCD 12X CD-ROM UniPack	1	
X6201A	14-GB, 4-mm tape Unipack	2	
X6208A	14-GB, 8-mm tape UniPack	2	
X6230A	20-GB to 40-GB, 8-mm tape drive UniPack	2	
X6251A	5-GB, 4-mm tape UniPack	2	
X6261A	4-GB to 8-GB, 4-mm DDS-2 drive	2	
X6280A	2-GB to 24-GB, 4-mm DDS-3 tape drive	2	



Part Number	Option Description	Maximum Number Supported	Comments
Mass Storage—Sun StorEdge UniPack (cont.)	<i>The following UniPack options come with a 50–68 pin SCSI cable:</i>		
X5102A	1.05-GB, 7200-rpm Fast/Wide SCSI-2 disk UniPack	4	NOTE: 68-pin is required on the Ultra 80 workstation; these options supported if the correct cable is substituted
X5152A	2.1-GB, 7200-rpm Fast/Wide SCSI-2 disk UniPack	4	
X6152A	SunCD 4X CD-ROM UniPack	1	
X6158A	SunCD 12X CD-ROM UniPack	2	
X6102A	2.5-GB QIC tape UniPack	2	
X6202A	14-GB, 8-mm tape UniPack	2	
X6209A	14-GB, 8-mm tape UniPack	2	
X6231A	20-GB to 40-GB, 8-mm tape drive	2	
X6252A	5-GB, 4-mm tape UniPack	2	
X6262A	4-GB to 8-GB, 4-mm DDS-2 tape drive	2	
X6281A	12-GB to 24-GB, 4-mm DDS-3 tape drive	2	
Mass Storage—MultiDisk Pack			
X569A	4.2-GB SCSI MultiDisk Pack (2 x 2.1-GB Fast SCSI-2 disk)	2	
X570A	8.4-GB SCSI MultiDisk Pack (4 x 2.1-GB Fast SCSI-2 disk)	1	
X739A	8.4-GB, 7200-rpm MultiDisk Pack (4 x 2.1-GB Fast SCSI-2 disk)	1	
X748A	8.4-GB SCSI MultiDisk Pack (2 x 4.2-GB Fast SCSI-2 disk)	2	
X749A	16.8-GB SCSI MultiDisk Pack (4 x 4.2-GB Fast SCSI-2 disk)	1	
X5211A	8.4-GB (2 x 4.2 GB), 7200-rpm Fast/Wide SCSI-2 MultiPack	2	
X5212A	16.8-GB (4 x 4.2 GB), 5400-rpm Fast/Wide SCSI-2 MultiPack	1	
X738A	4.2-GB, 7200-rpm MultiDisk Pack (2 x 2.1 GB)	2	



Part Number	Option Description	Maximum Number Supported	Comments
Mass Storage— Sun StorEdge FlexiPack	<i>The following FlexiPack options come with a 68–68 pin SCSI cable:</i>		NOTE: Order X3856A 68-pin to 68-pin SCSI cable with power cord for connecting a Sun StorEdge UniPack, FlexiPack, or MultiPack to Ultra 80 systems
SG-XTAP-DLT-020A	20-GB to 40-GB, DLT 4000 tape, desktop	2	
SG-XTAP-DLT-021A	35-GB to 70-GB, DLT 7000 tape, desktop	2	
SG-XTAP-4MM-020A	4-GB to 8-GB, 4-mm DDS-2 tape FlexiPack	2	
SG-XTAP-4MM-021A	12-GB to 24-GB, 4-mm DDS-3 tape FlexiPack	2	
SG-XTAP-4MM-031A	72-GB to 144-GB, 4-mm DDS-3 tape FlexiPack, desktop autoloader	2	
SG-XTAP-8MM-011A	20-GB to 40-GB, 8-mm tape in FlexiPack	2	
SG-XTAP-8MM-020A	14-GB, 8-mm tape FlexiPack	2	
SG-XTAP-8MM-021A	20-GB to 40-GB, 8-mm tape FlexiPack, desktop	2	
SG-XTAP-SLR-020A	4-GB SLR tape FlexiPack	2	
SG-XTAP-MLR-320A	25-GB to 50-GB MLR drive FlexiPack, desktop	2	
<i>SG-XTAP-8MM-011A</i>	<i>7-GB to 14-GB, 8-mm tape FlexiPack, desktop</i>	2	
X6106A	4-GB to 8-GB SLR internal tape drive	2	
X6166A	SunCD 32X CD-ROM	1	
X6057A	<i>DLT 4000 tape library</i>	2	
X6060A	<i>DLT 7000 tape library</i>	2	
X6210A	<i>14-GB, 8-mm tape FlexiPack</i>	2	
X6212A	12-GB to 24-GB, 4-mm DDS-3 internal tape drive	2	
X6232A	<i>20-GB to 40-GB, 8-mm tape FlexiPack</i>	2	
X6236A	20-GB to 40-GB, 8-mm internal tape for FlexiPack	2	
X6264A	<i>4-GB to 8-GB, 4-mm DDS-3 tape FlexiPack</i>	2	
X6282A	12-GB, to 24 GB, 4-mm DDS-3 tape internal	2	
X6284A	<i>112-GB to 24-GB, 4-mm DDS-3 tape FlexiPack</i>	2	
X6290A	<i>72-GB to 144-GB, 4-mm DDS-3 autoloader tape FlexiPack</i>	2	
	<i>The following FlexiPack options come with a 50–68 pin SCSI cable:</i>		NOTE: 68-pin is required on the Ultra 80 workstation; these options are supported if the correct cable is substituted
X6058A	<i>DLT 4000</i>	2	
X6061A	<i>DLT 7000</i>	2	
X6291A	<i>72-GB to 144-GB, 4-mm DDS-3 autoloader tape FlexiPack</i>	2	
X6285A	<i>12-GB to 24-GB, 4-mm DDS-3 tape FlexiPack</i>	2	
X6265A	<i>4-GB to 8-GB, 4-mm DDS-3 tape FlexiPack</i>	2	
X6150A	<i>SunCD 12X CD-ROM FlexiPack</i>	2	



Part Number	Option Description	Maximum Number Supported	Comments
Mass Storage— Sun StorEdge MultiPack			
SG-XDSK020A-8G	8.4-GB (2 x 4.2-GB) 7200-rpm MultiPack	1	NOTE: Order X3856A 68-pin to 68-pin SCSI cable with power cord for connecting a Sun StorEdge UniPack, FlexiPack, or MultiPack to Ultra 80 systems
SG-XDSK020A-18G	18.2-GB (2 x 9.1-GB) 7200-rpm MultiPack	1	
SG-XDSK020B-36G	36.4-GB (2 x 18.2-GB) 7200-rpm MultiPack	1	
SG-XDSK040A-16G	16.8-GB (4 x 4.2-GB) 7200-rpm MultiPack	1	
SG-XDSK040A-36G	36.4-GB (4 x 9.1-GB) 7200-rpm MultiPack	1	
SG-XDSK040B-72G	72.8-GB (4 x 18.2-GB) 7200-rpm MultiPack	1	
SG-XDSK060A-25G	25.2-GB (6 x 4.2-GB) 7200-rpm MultiPack	1	
SG-XDSK060A-54G	54.6-GB (6 x 9.1-GB) 7200-rpm MultiPack	1	
SG-XDSK060B-109G	109.2-GB (6 x 18.2-GB) 7200-rpm MultiPack	1	
SG-XLIBDLT1-280G	280-GB to 560-GB L280 tape autoloader (desktop)	1	
X5511A	4.2-GB (2 x 2.1-GB), 7200-rpm Fast/Wide SCSI-2 MultiPack	1	
X5512A	12.6-GB (6 x 2.1-GB), 7200-rpm Fast/Wide SCSI-2 MultiPack	1	
X5513A	25.2-GB (12 x 2.1-GB), 7200-rpm Fast/Wide SCSI-2 MultiPack	1	
X5514A	8.4-GB (2 x 4.2-GB), 7200-rpm Fast/Wide SCSI-2 MultiPack	1	
X5515A	25.2-GB (6 x 4.2-GB), 7200-rpm Fast/Wide SCSI-2 MultiPack	1	
X5516A	50.4-GB (12 x 4.2-GB), 7200-rpm Fast/Wide SCSI-2 MultiPack	1	
X5501A	8.4-GB (2 x 4.2-GB), 7200-rpm Fast/Wide SCSI-2 MultiPack	1	
X5502A	16.8-GB (4 x 4.2-GB), 7200-rpm Fast/Wide SCSI-2 MultiPack	1	
X5503A	25.2-GB (6 x 4.2-GB), 7200-rpm Fast/Wide SCSI-2 MultiPack	1	
X5504A	18.2-GB (2 x 9.1-GB), 7200-rpm Fast/Wide SCSI-2 MultiPack	1	
X5505A	36.4-GB (4 x 9.1-GB), 7200-rpm Fast/Wide SCSI-2 MultiPack	1	
X5506A	54.6-GB (6 x 9.1-GB), 7200-rpm Fast/Wide SCSI-2 MultiPack	1	
X6527A	18.2-GB MultiPack (2 x 9.1-GB), 7200-rpm UltraSCSI	1	
X6528A	36.4-GB MultiPack (4 x 9.1-GB), 7200-rpm UltraSCSI	1	
X6529A	18.2-GB MultiPack (6 x 9.1-GB), 7200-rpm UltraSCSI	1	



Part Number	Option Description	Maximum Number Supported	Comments
Mass Storage— Sun StorEdge Tape Libraries			
SG-XLIB8MM1-400G	400-GB to 800-GB 8-mm L400 tape library tower, 2 tape drives	1	
SG-XLIBDLT1-1TB	L1000 tape library deskside, 1 DLT 7000 tape drive	1	
SG-XLIBDLT4-1TB	L1000 tape library deskside, 4 DLT 7000 tape drive	1	
SG-XLIBDLT1R-1TB	L1000 tape library rackmount, 1 DLT 7000 tape drive	1	
SG-XLIBDLT4R-1TB	L1000 tape library rackmount, 4 DLT 7000 tape drive	1	
<i>SG-XLIB-8MM1-400G</i>	<i>400-GB L400, tower, two drives, barcode</i>	<i>1</i>	
<i>SG-XLIB-DLT1-280G</i>	<i>Sun StorEdge L280 autoloader, desktop</i>	<i>1</i>	
X6225A	<i>SPARCstorage™ Library Model 8/400</i>		
X6227A	<i>SPARCstorage Library Model 140-GB L140, tower, one drive</i>	<i>1</i>	
X849A	<i>SPARCstorage Library Model 8/140, 140-GB, 8-mm stackable unit</i>	<i>1</i>	
X6073	Sun StorEdge L1800 with 2 DLT 7000 tape drives, 52 slots	1	
X6074	Sun StorEdge L1800 with 4 DLT 7000 tape drives, 52 slots	1	
X6075	Sun StorEdge L1800 with 2 DLT 7000 tape drives, 100 slots	1	
X6076	Sun StorEdge L1800 with 7 DLT 7000 tape drives, 100 slots	1	
X867A	<i>SPARCstorage Library Model 8/140, 140-GB, 8-mm, two drives and barcode reader, tower unit</i>	<i>1</i>	
X869X	<i>SPARCstorage Library Model 8/140, 140-GB, 8-mm, two drives and barcode reader, stackable unit</i>	<i>1</i>	

Part Number	Option Description	Maximum Number Supported	Comments
Mass Storage— Sun StorEdge A1000 and D1000 Arrays			
SG-XARY144A-36G	36-GB Sun StorEdge A1000 array		
SG-XARY144A-109G	109-GB Sun StorEdge A1000 array		
SG-XARY151A-72G	72-GB Sun StorEdge A1000 array		
SG-XARY151A-218G	218-GB Sun StorEdge A1000 array		
SG-XARY161A-145G	145-GB Sun StorEdge A1000 array		
SG-XARY161A-291G	291-GB Sun StorEdge A1000 array		
SG-XARY146A-36G	36-GB Sun StorEdge A1000 array for rackmount		
SG-XARY152A-72G	72-GB Sun StorEdge A1000 array for rackmount		
SG-XARY162A-145G	145-GB Sun StorEdge A1000 array for rackmount		
SG-XARY145A-36G	36-GB Sun StorEdge D1000 array		
SG-XARY145A-109G	109-GB Sun StorEdge D1000 array		
SG-XARY153A-72G	72-GB Sun StorEdge D1000 array		
SG-XARY153A-218G	218-GB Sun StorEdge D1000 array		
SG-XARY163A-145G	145-GB Sun StorEdge D1000 array		
SG-XARY163A-291G	291-GB Sun StorEdge D1000 array		
SG-XARY147A-36G	36-GB Sun StorEdge D1000 array for rackmount		
SG-XARY154A-72G	72-GB Sun StorEdge D1000 array for rackmount		
SG-XARY164A-145G	145-GB Sun StorEdge D1000 array for rackmount		
X5235A	9.1-GB, 10000-rpm, 1-inch UltraSCSI disk drive		
X5233A	18-GB, 7200-rpm, 1.6-inch UltraSCSI disk drive		
X5238A	18.2-GB, 10000-rpm, 1-inch UltraSCSI disk drive		
X5240A	36.4-GB, 10000-rpm, 1.6-inch UltraSCSI disk drive		
X7040A	64-MB add-on cache memory		
SG-XARY030A	Sun StorEdge empty rack		
X9653A	Sun StorEdge/Sunfire™ server rackmount kit		
X9818A	Front door assembly for 72-inch StorEdge rack		
X9606A	Tower stand kit		
ARRAYNT-6221-B	Volume management software for Microsoft Windows NT hosts		

Part Number	Option Description	Maximum Number Supported	Comments
Mass Storage— Sun StorEdge A3500 Arrays			
SG-ARY370A-91G	91-GB Sun StorEdge A3500 array, configure to order		
SG-ARY372A-182G	182-GB Sun StorEdge A3500 array, configure to order		
SG-ARY374A-273G	273-GB Sun StorEdge A3500 array, configure to order		
SG-ARY380A-182G	182-GB Sun StorEdge A3500 array, fixed configuration		
SG-ARY382A-364G	364-GB Sun StorEdge A3500 array, configure to order		
SG-ARY384A-546G	546-GB Sun StorEdge A3500 array, configure to order		
SG-XARY360A-545G	545-GB Sun StorEdge A3500 array, fixed configuration		
SG-XARY380A-1092G	1092-GB Sun StorEdge A3500 array, fixed configuration		
SG-XARY381A-1456G	1456-GB Sun StorEdge A3500 array, fixed configuration		
SG-ARY381A-364G	364-GB Sun StorEdge A3500 array, configure to order		
SG-ARY383A-728G	728-GB Sun StorEdge A3500 array, configure to order		
SG-ARY385A-1092G	1092-GB Sun StorEdge A3500 array, configure to order		
SG-XARY366A-72G	72-GB Sun StorEdge A3500 array, fixed configuration		
SG-XARY147A-36G	Sun StorEdge D1000 rackmount tray with 4 x 9-GB, 10000-rpm disks		
SG-XARY154A-72G	Sun StorEdge D1000 rackmount tray with 4 x 18-GB, 10000-rpm disks		
SG-XARY164A-145G	Sun StorEdge D1000 rackmount tray with 4 x 36-GB, 10000-rpm disks		
X6537A	Sun StorEdge A3500 controller module		
X7020A	Sun StorEdge A3000 array 64-MB add-on cache memory		
X5235A	9.1-GB, 10000-rpm UltraSCSI disk		
X5233A	18-GB, 7200-rpm UltraSCSI disk		
X5238A	18-GB, 10000-rpm UltraSCSI disk		
X5240A	36-GB, 7200-rpm UltraSCSI disk		
ARRAYNT-6221-B	Volume management software for Microsoft Windows NT hosts		
X9818A	Front door assembly for 72-inch Sun StorEdge rack		
SG-XARY030A	Sun StorEdge expansion cabinet		

Part Number	Option Description	Maximum Number Supported	Comments
Mass Storage— Sun StorEdge A5X00 Arrays			
SG-XARY530A-254G	254-GB Sun StorEdge A5100 array		
SG-XARY530A-91G	91-GB Sun StorEdge A5100 array		
SG-XARY533A-1528G	1528-GB Sun StorEdge A5100 array		
SG-XARY533A-509G	509-GB Sun StorEdge A5100 array		
SG-XARY533A-254G	254-GB Sun StorEdge A5100 array		
SG-XARY531A-254G	254-GB Sun StorEdge A5100 array		
SG-ARY532A-254G	254-GB Sun StorEdge A5100 array		
SG-XARY520A-200G	200-GB Sun StorEdge A5200 array		
SG-XARY520A-63G	63-GB Sun StorEdge A5200 array		
SG-XARY523A-800G	800-GB Sun StorEdge A5200 array		
SG-XARY523A-400G	400-GB Sun StorEdge A5200 array		
SG-ARY523A-200G	200-GB Sun StorEdge A5200 array, hubless		
SG-XARY521A-200G	200-GB Sun StorEdge A5200 array		
SG-ARY522A-200G	200-GB Sun StorEdge A5200 array		
6710A	9.1-GB, 10000-rpm FC-AL disk drive (A5200)		
6711A	18.2-GB, 7200-rpm FC-AL disk drive (A5100)		
6730A	100-MB/sec. FC-AL SBus dual-channel host adapter, including one GBIC module		
6729A	100-MB/sec. FC-AL PCI single-channel host adapter		
6731A	100-MB/sec. FC-AL GBIC for host adapter or hub		
X6737A	Long-Wave optical module; includes one Long-Wave GBIC module; one 15-meter, single-mode, fibre optic jumper cable		
6732A	100-MB/sec. FC-AL seven-port hub, no GBICs included		
6735A	Hub rackmounting kit		
X6734A	Interface board with one GBIC		
X9687A	Power supply		
X9654A	Array rackmounting kit for Sun StorEdge cabinet		
X9655A	Array rackmounting kit for Sun Enterprise system cabinet		
X9818A	Front door assembly for 72-inch Sun StorEdge rack		
X973A	2-meter fibre optic cable		
X978A	15-meter fibre optic cable		
A5200-INSTALL	Sun StorEdge ArrayStart SM Installation Service; includes on-site installation of factory configured Sun StorEdge A5X00 arrays		
FWCACHE-INSTALL	Installation and initial configuration services for Sun StorEdge Fast Write Cache		

Part Number	Option Description	Maximum Number Supported	Comments
Input Devices			
X180A	SunButtons™ 32-key function I/O device	1	
X190A	SunDials™ 8-dial interactive graphics I/O device for 3-D	1	
PCI Expansion Cards			
X1032A	10/100BASE-T Ethernet with SunPCI™ UltraSCSI	4	
X1034A	Sun Quad FastEthernet™ PCI Card (QFE)	1	
X1035A	SunFDDI™ single-attach PCI adapter (SAS/5.0)	3	
X1036A	SunFDDI dual-attach PCI adapter (DAS/5.0)	3	
X1039A	SunLink™ token ring interface/PCI adapter	2	
X1040A	High-speed serial interface PCI adapter (SunHSI™) (1 port)	3	Universal
X1041A	Serial asynchronous interface (SunSAI) PCI adapter	4	
X1066A	SunATM™/P-155MMF 3.0 PCI Bus adapter	2	
X1067A	SunATM/P-155UTP 3.0 PCI Bus adapter	2	
X1068A	SunATM/P-622MMF 3.0 PCI Bus adapter	1	
X1089A	SunVideo Plus™ video/audio capture	3	
X499A	PCI Multimedia Kit, SunVideo Plus, a PAL SunCamera™ II, Sun Microphone™ II, and documentation		
X1141A	Sun GigabitEthernet PCI adapter 2.0	1	
X3668A	PGX32 8- and 24-bit color graphics PCI adapter frame buffer, CD, and cable	3	
X6540A	Dual-channel, single-ended UltraSCSI controller	2	
X6541A	Dual-channel, differential UltraSCSI controller	3	
X1131A-64.2	SunPCi™ 400-MHz K6-2 co-processor card, 64-MB memory	1	
Monitors and Graphics			
X3660A	PGX™ 8-bit color graphics PCI adapter frame buffer and cable	3	
X3668A	PGX32 8- and 24-bit color graphics PCI adapter frame buffer, CD, and cable	3	
X3664A	Sun Elite3D m3 graphics accelerator	2	
X3665A	Sun Elite3D m6 graphics accelerator	1	
X7103A	<i>Entry-level 17-inch color monitor</i>		
X7119A	<i>19-inch color monitor</i>		
X267A	<i>20-inch color monitor</i>		
X7121A	<i>21-inch color monitor</i>		
X7135A	19-inch flat screen color Trinitron monitor		
X7136A	21-inch flat screen color Trinitron monitor		
X7127A	18.1-inch flat panel LCD display		
X3872A	HD15-pin video output (for 17-inch and 19-inch monitors)		



System Upgrades

Sun upgrades offer customers outstanding investment protection for their existing Sun equipment.

Key Messages

- Sun offers customers a variety of flexible upgrade paths to the most popular Sun systems
- Choose from chassis-only to full-system upgrades
- Sun upgrades allow as many components as possible to be carried forward, to protect the customer's hardware investment
- Existing investments in non-Sun hardware can be preserved by upgrading to Sun through competitive full-system upgrades
- SPARCstation 20 or Ultra upgrades offer outstanding value by allowing the migration of memory to Sun Ultra 80 systems

Sun Ultra 80 Workstation Upgrade Paths

From	Receive	Return
Full system upgrade from Any SPARCstation or Ultra to Ultra 80 workstation	Complete Ultra 80 system	Complete SPARCstation or Ultra workstation
Competitive upgrade to Ultra 80 workstation	Complete Ultra 80 system	Complete competitive workstation

Marketing Upgrade Numbering Scheme

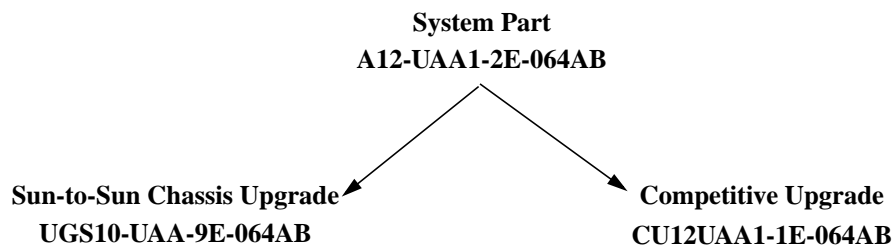

- The differences between the upgrade and system part numbers lie in the first eight characters; the ten trailing characters carry the same interpretation as system parts.
- Sun-to-Sun upgrades begin with U or UG; competitive upgrades begin with CU.
- Sun-to-Sun upgrades show the “from” path system in the first three characters that follow the U or UG.
- Character representations following the “from” system have the same interpretation as system parts, but dashes may be removed from left to right, as necessary, to meet the maximum part number length of 18 characters.

Module Upgrades

Part Number

UG-MXXX-M450

Model 1300

Module upgrade to 450-MHz UltraSPARC-II with 4-MB L2 cache

Upgrade to Sun Ultra 80 Workstation Model 1450

Part Number

UG23-7ULD19T-000AQ

Model 1450

Chassis upgrade from Ultra 2 or Ultra 60 to Sun Ultra 80 Model 1450, 450-MHz UltraSPARC-II with 4-MB Cache, PGX32 PCI graphics, no memory, 18-GB 10000-rpm UltraSCSI internal disk, 10/100BASE-T Ethernet.

UG23-7ULD19T-256AQ

Chassis upgrade from Ultra 2 or Ultra 60 to Sun Ultra 80 Model 1450, 450-MHz UltraSPARC-II with 4-MB cache, PGX32 graphics, 256-MB memory, 18-GB 10000-rpm UltraSCSI internal disk, 10/100BASE-T Ethernet.

UG23-7ULD19T1024AQ

Chassis upgrade from Ultra 2 or Ultra 60 to Sun Ultra 80 Model 1450, 450-MHz UltraSPARC-II with 4-MB cache, PGX32 graphics, 1024-MB memory, 18-GB 10000-rpm UltraSCSI internal disk, 10/100BASE-T Ethernet.

UG23-7ULD19M1024AQ

Chassis upgrade from Ultra 2 or Ultra 60 to Sun Ultra 80 Model 1450, 450-MHz UltraSPARC-II with 4-MB cache, Sun Elite3D m6 graphics, 1024-MB memory, 18-GB 10000-rpm UltraSCSI internal disk, 10/100BASE-T Ethernet.

UG23-7ULD19N1024AQ

Chassis upgrade from Ultra 2 or Ultra 60 to Sun Ultra 80 Model 1450, 450-MHz UltraSPARC-II with 4-MB cache, No graphics, 1024-MB memory, 18-GB 10000-rpm UltraSCSI internal disk, 10/100BASE-T Ethernet.

UG16-7ULD19T-256AQ

Chassis upgrade from Ultra 1 or Ultra 30 to Sun Ultra 80 Model 1450, 450-MHz UltraSPARC-II with 4-MB cache, PGX32 graphics, 256-MB memory, 18-GB 10000-rpm UltraSCSI internal disk, 10/100BASE-T Ethernet.

UG16-7ULD19T1024AQ

Chassis upgrade from Ultra 1 or Ultra 30 to Sun Ultra 80 Model 1450, 450-MHz UltraSPARC-II with 4-MB cache, PGX32 graphics, 1-GB memory, 18-GB 10000-rpm UltraSCSI internal disk, 10/100BASE-T Ethernet.

UG16-7ULD19M1024AQ	Chassis upgrade from Ultra 1 or Ultra 30 to Sun Ultra 80 Model 1450, 450-MHz UltraSPARC-II with 4-MB cache, Sun Elite3D m6 graphics, 1-GB memory, 18-GB 10000-rpm UltraSCSI internal disk, 10/100BASE-T Ethernet.
UG20-7ULD19T-256AQ	Chassis upgrade from SPARCstation 10 or 20 to Sun Ultra 80 Model 1450, 450-MHz UltraSPARC-II with 4-MB cache, PGX32 graphics, 256-MB memory, 18-GB 10000-rpm UltraSCSI internal disk, 10/100BASE-T Ethernet.
UG20-7ULD19T1024AQ	Chassis upgrade from SPARCstation 10 or 20 to Sun Ultra 80 Model 1450, 450-MHz UltraSPARC-II with 4-MB cache, PGX32 graphics, 1-GB memory, 18-GB 10000-rpm UltraSCSI internal disk, 10/100BASE-T Ethernet.
UG20-7ULD19M1024AQ	Chassis upgrade from SPARCstation 10 or 20 to Sun Ultra 80 Model 1450, 450-MHz UltraSPARC-II with 4-MB cache, Sun Elite3D m6 graphics, 1-GB memory, 18-GB 10000-rpm UltraSCSI internal disk, 10/100BASE-T Ethernet.
UGES-7ULD19T-256AQ	Chassis upgrade from early SPARCstation systems to Sun Ultra 80 Model 1450, 450-MHz UltraSPARC-II with 4-MB cache, PGX32 graphics, 256-MB memory, 18-GB 10000-rpm UltraSCSI internal disk, 10/100BASE-T Ethernet.
UGES-7ULD19T1024AQ	Chassis upgrade from early SPARCstation systems to Sun Ultra 80 Model 1450, 450-MHz UltraSPARC-II with 4-MB cache, PGX32 graphics, 1-GB memory, 18-GB 10000-rpm UltraSCSI internal disk, 10/100BASE-T Ethernet.
UGES-7ULD19M1024AQ	Chassis upgrade from early SPARCstation systems to Sun Ultra 80 Model 1450, 450-MHz UltraSPARC-II with 4-MB cache, Sun Elite3D m6 graphics, 1-GB memory, 18-GB 10000-rpm UltraSCSI internal disk, 10/100BASE-T Ethernet.

Upgrade to Sun Ultra 80 Workstation Model 2450

Part Number

Model 1360

UG23-7ULD29N1024AQ

Chassis upgrade from Ultra 2 or Ultra 60 to Sun Ultra 80 Model 2450, 2x450-MHz UltraSPARC-II with 4-MB cache, No graphics, 1024-MB memory, 18-GB 10000-rpm UltraSCSI internal disk, 10/100BASE-T Ethernet.

UG23-7ULD29T1024AQ

Chassis upgrade from Ultra 2 or Ultra 60 to Sun Ultra 80 Model 2450, 2x450-MHz UltraSPARC-II with 4-MB cache, PGX32 graphics, 1024-MB memory, 18-GB 10000-rpm UltraSCSI internal disk, 10/100BASE-T Ethernet.

UG23-7ULD29M1024AQ

Chassis upgrade from Ultra 2 or Ultra 60 to Sun Ultra 80 Model 2450, 2x450-MHz UltraSPARC-II with 4-MB cache, Sun Elite3D m6 graphics, 1024-MB memory, 18-GB 10000-rpm UltraSCSI internal disk, 10/100BASE-T Ethernet.

UG16-7ULD29T1024AQ

Chassis upgrade from Ultra 1 or Ultra 30 to Sun Ultra 80 Model 2450, 450-MHz UltraSPARC-II with 4-MB cache, PGX32 graphics, 1-GB memory, 18-GB 10000-rpm UltraSCSI internal disk, 10/100BASE-T Ethernet.

UG16-7ULD29M1024AQ

Chassis upgrade from Ultra 1 or Ultra 30 to Sun Ultra 80 Model 2450, 450-MHz UltraSPARC-II with 4-MB cache, Sun Elite3D m6 graphics, 1-GB memory, 18-GB 10000-rpm UltraSCSI internal disk, 10/100BASE-T Ethernet.

UG20-7ULD29T1024AQ

Chassis upgrade from SPARCstation 10 or 20 to Sun Ultra 80 Model 2450, 2x450-MHz UltraSPARC-II with 4-MB cache, PGX32 graphics, 1024-MB memory, 18-GB 10000-rpm UltraSCSI internal disk, 10/100BASE-T Ethernet.

UG20-7ULD29M1024AQ

Chassis upgrade from SPARCstation 10 or 20 to Sun Ultra 80 Model 2450, 2x450-MHz UltraSPARC-II with 4-MB cache, Sun Elite3D m6 graphics, 1024-MB memory, 18-GB 10000-rpm UltraSCSI internal disk, 10/100BASE-T Ethernet.

UGES-7ULD29T1024AQ

Chassis upgrade from early SPARCstation systems to Sun Ultra 80 Model 2450, 450-MHz UltraSPARC-II with 4-MB cache, PGX32 graphics, 1-GB memory, 18-GB 10000-rpm UltraSCSI internal disk, 10/100BASE-T Ethernet.

UGES-7ULD29M1024AQ

Chassis upgrade from early SPARCstation systems to Sun Ultra 80 Model 2450, 450-MHz UltraSPARC-II with 4-MB cache, Sun Elite3D m6 graphics, 1-GB memory, 18-GB 10000-rpm UltraSCSI internal disk, 10/100BASE-T Ethernet.

Competitive Upgrades to Sun Ultra 80 Workstation

Part Number	Description
CU-A27ULD19T-256AQ	Chassis upgrade from non-Sun workstations to Sun Ultra 80 Model 1450, 450-MHz UltraSPARC-II with 4-MB cache, PGX32 graphics, 256-MB memory, 18-GB 10000-rpm UltraSCSI internal disk, 10/100BASE-T Ethernet.
CU-A27ULD19T1024AQ	Chassis upgrade from non-Sun workstations to Sun Ultra 80 Model 1450, 450-MHz UltraSPARC-II with 4-MB cache, PGX32 graphics, 1-GB memory, 18-GB 10000-rpm UltraSCSI internal disk, 10/100BASE-T Ethernet.
CU-A27ULD19M1024AQ	Chassis upgrade from non-Sun workstations to Sun Ultra 80 Model 1450, 450-MHz UltraSPARC-II with 4-MB cache, Sun Elite3D m6 graphics, 1-GB memory, 18-GB 10000-rpm UltraSCSI internal disk, 10/100BASE-T Ethernet.

Upgrade Ordering Notes

- Memory migrates from Ultra 1 and Ultra 2 workstations; disks do not migrate
- 300-MHz modules from the Ultra 2 and Ultra 30 will not migrate
- Graphics cards from A12, A14 do not migrate
- Monitors
 - Monitors are not included with any Ultra 80 system upgrades
 - Sun branded 17-inch and 20-inch monitors migrate from previous generation Sun systems
 - For some monitors, a video adapter may be required. Please order correct adapter (i.e., 21-inch color monitor with on-board 8-bit graphics requires X470A). Adapter choices are:
 - X3872A—HD15F to 13W3 video adapter
 - X470A—13W3F to HD15M video adapter (10-inch cable)
 - If a monitor is needed, order an X-option or refer to monitor upgrade section of price book
- Country Kits
 - Type 4 keyboards are not supported on the Ultra 80 workstation.
 - Type 5 keyboards can migrate to the Ultra 80 workstation.

Service and Support

The SunSpectrumSM program is an innovative and flexible service offering that allows customers to choose the level of service best suited to their needs, ranging from mission-critical support for maximum solution availability to backup assistance for self-support customers. The SunSpectrum program provides a simple pricing structure in which a single fee covers support for an entire system, including related hardware and peripherals, the SolarisTM Operating Environment software, and telephone support for SunTM software packages. The majority of Sun's customers today take advantage of the SunSpectrum program, underscoring the value that it represents. Customers should check with their local Sun Enterprise Services representatives for program and feature availability in their areas.

FEATURE	SUNSPECTRUM PLATINUM SM Mission-critical Support	SUNSPECTRUM GOLD SM Business-critical Support	SUNSPECTRUM SILVER SM Systems Support	SUNSPECTRUM BRONZE SM Self Support
Systems Features				
Systems approach coverage	Yes	Yes	Yes	Yes
System availability guarantee	Customized	No	No	No
Account Support Features				
Service account management team	Yes	No	No	No
Local customer support management	No	Yes	No	No
Personal technical account support	Yes	Yes	Option	No
SunStart TM installation service	Yes	No	No	No
Account support plan	Yes	Yes	No	No
Software release planning	Yes	No	No	No
On-site account reviews	Monthly	Semiannual	No	No
Skills assessment	Yes	No	No	No
Site activity log	Yes	Yes	No	No
Coverage / Response Time				
Standard telephone coverage hours	7 day/24 hour	7 day/24 hour	8 a.m.–8 p.m., Monday–Friday	8 a.m.–5 p.m., Monday–Friday
Standard on-site coverage hours	7 day/24 hour	8 a.m.–8 p.m., Monday–Friday	8 a.m.–5 p.m., Monday–Friday	N/A
7-day/24-hour telephone coverage	Yes	Yes	Option	Option
7-day/24-hour on-site coverage	Yes	Option	Option	N/A
7-day/12-hour on-site coverage	No	Option	No	No
5-day/24-hour on-site coverage	No	Option	No	No

FEATURE	SUNSPECTRUM PLATINUM SM Mission-critical Support	SUNSPECTRUM GOLD SM Business-critical Support	SUNSPECTRUM SILVER SM Systems Support	SUNSPECTRUM BRONZE SM Self Support
Coverage / Response Time (cont.)				
Customer-defined priority setting	Yes	Yes	Yes	Option
• Urgent (phone/on-site)	Live transfer/ 2 hour	Live transfer/ 4 hour	Live transfer/ 4 hour	4 hour / N/A
• Serious (phone/on-site)	Live transfer/ 4 hour	2 hour/next day	2 hour/next day	4 hour / N/A
• Not critical (phone/on-site)	Live transfer/ customer convenience	4 hour/ customer convenience	4 hour/ customer convenience	4 hour / N/A
2-hour on-site response	Yes	Option	Option	N/A
Additional contacts	Option	Option	Option	Option
Premier Support Features				
Mission-critical support team	Yes	For urgent problems	No	No
Sun Vendor Integration Program (SunVIP SM)	Yes	Yes	No	No
Software patch management assistance	Yes	No	No	No
Field change order (FCO) management assistance	Yes	No	No	No
Hardware Support Delivery				
Replacement hardware parts	On-site technician	On-site technician	On-site technician	Courier
Two day parts delivery	N/A	N/A	N/A	Yes
Overnight parts delivery	N/A	N/A	N/A	Option
Same-day parts delivery	Yes	Yes	Yes	Option
Remote Systems Diagnostics				
Remote dial-in analysis	Yes	Yes	Yes	Yes
Remote systems monitoring	Yes	Yes	No	No
Remote predictive failure reporting	Yes	Yes	No	No
Software Enhancements and Maintenance Releases				
Solaris enhancement releases	Yes	Yes	Yes	Yes
Patches and maintenance releases	Yes	Yes	Yes	Yes
Sun unbundled software enhancements	Option	Option	Option	Option
Internet and CD-ROM Support Tools				
SunSolve TM license	Yes	Yes	Yes	Yes
SunSolve EarlyNotifier SM Service	Yes	Yes	Yes	Yes



SunClientSM

Now there is a way to reduce hardware and software support costs for JavaStationTM network computers and UltraTM workstations. The SunClientSM support program is a suite of offerings that is separate, yet complementary to the SunSpectrum program. SunClient support provides:

- A choice for optimizing low-cost workstation support
- Flexibility to select only the services needed
- Administrative simplicity, saving time and money
- Access to world-class UNIX[®] networking experts

FEATURE	SunClient Maintenance	SunClient Central Maintenance	SunClient SW Tech Support Option*
Systems approach coverage	*	*	
Solaris and unbundled software technical support			*
9 a.m.-5 p.m., M-F telephone coverage	*	*	*
8 a.m.-5 p.m., M-F on-site coverage	*†‡	*‡	
Response times (phone/onsite)	4 hr. callback/next business day response	4 hr. callback/second business day response	4 hr. callback
Centralized on-site repair of multiple units		*	Not Applicable
Patches	Not Applicable	Not Applicable	*
SunSolve license	Not Applicable	Not Applicable	*
SunSolve EarlyNotifier Service	Not Applicable	Not Applicable	*
Software updates	Not Applicable	Not Applicable	Not Applicable
<p>* Can only be sold as an option to SunClient Maintenance or SunClient Central Maintenance.</p> <p>† Next business day on-site response requires that the request for service be received by 3:00 p.m. If the call is received after 3:00.p.m., service will be provided on the second business day.</p> <p>‡ Customers located more than 50 miles from an authorized service provider or reseller will be charged an additional fee for service activity.</p>			

Features and Benefits of the SunClient Program

Features

- Unbundled hardware and software support
- Next business day (SunClient Maintenance) or second business day (SunClient Central Maintenance) on-site response
- Single contract with choice of automatic warranty upgrade
- SunClient Central Maintenance
- Service delivery by Sun experts

Benefits

- *Flexibility*
Select the type and amount of coverage needed for desktop systems, so service dollars are targeted where they are needed most.
- *Cost savings*
Pay only for the support services needed.
- *Cost efficiency*
Because Sun can more efficiently manage spare inventory and labor scheduling, the savings can be passed on to the customer.
- *Simplicity*
One contract covers a predefined number of systems at one low price. New systems acquired can be upgraded to the SunClient service level.
- *Cost savings*
Sun realizes an economy of scale by repairing multiple systems with one visit and leverages existing support infrastructures, so cost efficiency is maximized while duplication of effort is virtually eliminated.
- *Consistency*
Selected desktops can be deployed virtually anywhere, enabling cost-effective, quality service and support.

For more information, visit the SunClient support (external) web site at:
<http://www.sun.com/service/support/sunclient>

Glossary

24-bit color	The ability to render objects from a palette of 16.7 million colors. It is often referred to as true color and results in much more realistic shading of 3-D objects for enhanced image quality.
3D-RAM	Dual-ported video memory with graphics functionality built into the memory chip.
100BASE-T	See Fast Ethernet.
antialiasing	A graphics technique that greatly enhances the quality of images by eliminating many of the inaccuracies (“jaggies”) inherent to rendering on a raster display. Typically found only in high-end graphics systems.
DIMM	Dual inline memory module. A memory unit that can come in a variety of sizes, such as 16 MB, 32 MB, 64 MB, and 128 MB.
Fast Ethernet	IEEE standard for 100-Mb Ethernet. This technology supports a data transfer rate of 100 megabits per second over special grades of twisted-pair wiring.
NFS™	Sun’s distributed computing file system.
ODBC	Open database connectivity.
OpenGL®	The de facto standard software interface for graphics hardware that allows programmers to create interactive 3-D applications. The OpenGL API provides a full-featured, network-transparent application programming interface.
PCI	Peripheral component interconnect. A industry-standard for connecting peripherals such as disk drives, tapes drives, and other devices used in the PCs.
PLBwire93	The Picture Level Benchmark for wireframe performance. A benchmark standardized by the National Computer Graphics Associated GPC committee. The value represents the geometric mean performance on several commonly used 3-D wireframe operations.
PLBsurf93	The Picture Level Benchmark for 3-D surface performance. A benchmark standardized by the National Computer Graphics Associated GPC committee. The value represents the geometric mean performance on several commonly used 3-D surface operations.
UPA	Ultra™ port architecture. A high-speed, crossbar-oriented, packet-switched mother board interconnect.
V9	Version 9 of the SPARC™ definition.

VIS™

Visual instruction set. The UltraSPARC™ processor implements a special instruction set that is primarily aimed at image and video processing. Some of the instructions allow the CPU to directly access and operate on image data with a high degree of parallelism. Other instructions provide facilities for formatting and moving data at very high rates of speed both within the CPU, and between the CPU and the other system components.

XGL™

A foundation geometry-oriented 2-D/3-D graphics library that provides high functionality and performance to geometry applications and application program interfaces (APIs).

XIL™

X imaging library. A foundation imaging-oriented graphics library providing high functionality and performance to imaging applications.

Materials Abstract

All materials are available on SunWIN except where noted otherwise.

Collateral	Description	Purpose	Distribution	Token # or COMAC Order #
PowerPack				
– <i>Sun Ultra™ 80 Workstation: Just the Facts</i>	Reference Guide for Sun Ultra 80 Workstation (this document)	Training Sales Tool	SunWIN, Reseller Web	110090
– <i>Sun in EDA Customer Presentation</i>	Presentation	Sales Tool	SunWIN, Reseller Web	59078 59260
– <i>Sun in MCAD/MCAE Customer Presentation</i>	Presentation	Sales Tool	SunWIN, Reseller Web	59074 59263
– <i>Sun in Software Development Customer Presentation</i>	Presentation	Sales Tool	SunWIN, Reseller Web	59375
– <i>Sun in Oil and Gas Customer Presentation</i>	Presentation	Sales Tool	SunWIN, Reseller Web	60292 60297
– <i>Sun in Entertainment Customer Presentation</i>	Presentation	Sales Tool	SunWIN	75241 75242
– <i>Sun Ultra 80 Workstation Customer Presentation</i>	Presentation	Sales Tool	SunWIN, Reseller Web	TBD
– <i>Graphics Overview Presentation</i>	Presentation	Sales Tool	SunWIN, Reseller Web	75254 75255
References				
– <i>Sun™ Elite3D Graphics: Just the Facts, 1/98</i>	Reference Guide for Sun Elite3D m6	Training Sales Tool	SunWIN, Reseller Web	75245
– <i>SunVideo Plus™: Just the Facts</i>	Reference Guide for Sun Video Plus	Training Sales Tool	SunWIN, Reseller Web	75247
– <i>Quick Reference Card—Sun Workstation™ Product Line Overview</i>	Quick Reference Card	Sales Tool	SunWIN, Reseller Web, First Resort	10826
– <i>Quick Reference Card—Sun Workstation Graphics Products Overview</i>	Quick Reference Card	Sales Tool	SunWIN, Reseller Web, First Resort	24507
– <i>Quick Reference Card—Competitive Summary Workstations</i>	Quick Reference Card	Sales Tool	SunWIN, Reseller Web, First Resort	12259
– <i>Quick Reference Card—Upgrade Paths</i>	Quick Reference Card	Sales Tool	SunWIN, Reseller Web, First Resort	24513
Product Literature				
– <i>Graphics Solution Guide</i>	Graphics Overview	Sales Tool	SunWIN	75271
Web Sites				
– <i>Sun Workstations Overview Page</i>	http://www.sun.com/desktop			